

REVISION HISTORY			
REV	DESCRIPTION	Drawing	DATE
06	TITLE 增加說明	Allen	2022/07/11

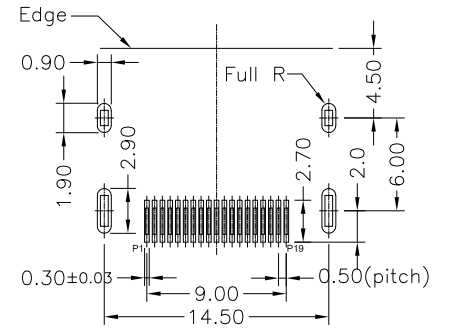

RECOMMENDED PCB LAYOUT (TOP VIEW)
GENERAL TOLERANCES: ±0.05 (t=1.6)

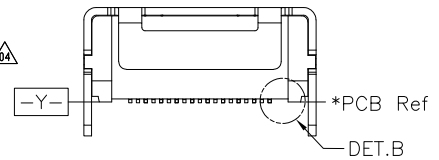
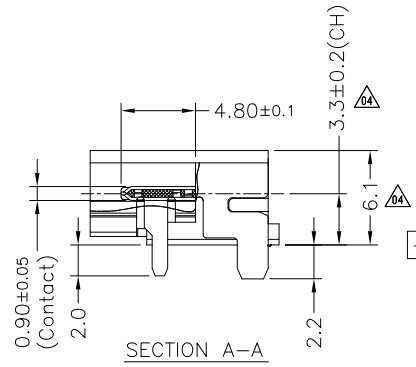
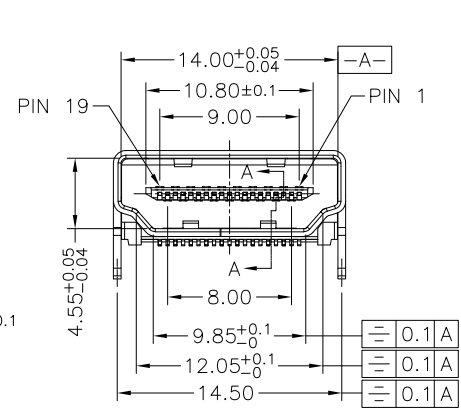
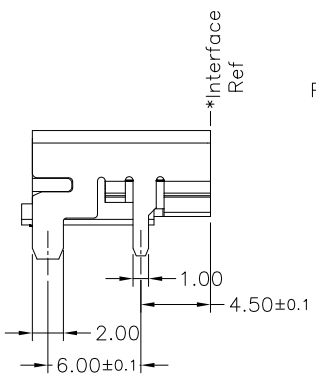
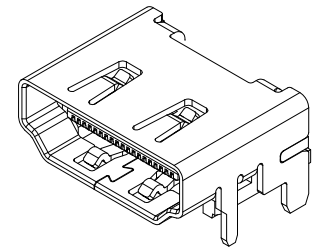
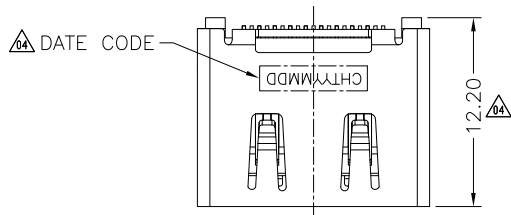
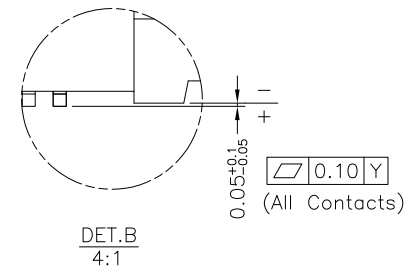
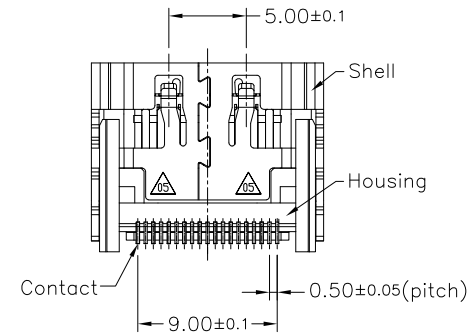

- NOTES:
- MATERIAL AND PLATING:
Housing: LCP+30%G.F,UL94V-0,Black
Contact: COPPER ALLOY
Shell: SPCC
Mylar: Polyimide Film(Optional)
 - PLATING:
CONTACT: GOLD PLATING
80 μ" MIN. MATTE-TIN ON SOLDERING TAILS
50 μ" MIN. NICKEL UNDERPLATING OVER
SHELL: 50μ" MIN. NICKEL UNDERPLATING OVER ALL
 - MECHANICAL CHARACTERISTIC
Mating Force: 44.1N(4.5Kgf) max.
Unmating Force: 9.8N~39.2(1~4Kgf).
Durability: 10,000 Cycles.
 - ELECTRICAL CHARACTERISTIC
Contact Resistance: 30m Ohm Max.
Insulation Resistance: 100M Ohm Min(unmated)
10M Ohm Min(mated)
Dielectric Withstanding Voltage: 500V AC Min
 - TEMPERATURE
Operating Temperature: -40°C~+85°C
Storage Temperature: -60°C~+105°C

TABLE Δ

FIH P/N	GOLD THICKNESS
A0314-0001	G/F Au
A0314-0008	3u" Au

PRODUCT SPECIFICATION: DOC.No: SP-AXXX-XX	SCALE 1 : 1	DESIGN UNITS mm
TEST REPORT DOC.No: TR-AXXX-XX	DRAWN Mei Chen	DATE 2014/11/20
GENERAL TOLERANCES (UNLESS SPECIFIED)	CHECKED	DATE
X.XXX ± 0.10	APPROVED	DATE
X.XX ± 0.25	DWG NO. SA0314-001	
X.X ± 0.38		
ANGULAR ± 3°		
THIRD ANGLE PROJECTION		

CHT 群匯科技股份有限公司
CHIUN HUEI Technology CO., LTD.

TITLE Δ
HDMI 2.0 A Type Receptacle SMT

PART NO. TABLE A	DWG REV. 06	SHEET NO. 1 OF 1
---------------------	----------------	---------------------

REVISION HISTORY			
REV	DESCRIPTION	Drawing	DATE
04	TITLE增加說明	Allen	2022/07/11

PACKAGING INSTRUCTION I:

1. STAPLES SHOULD ONLY BE USED TO SET UP CARTON ALL CARTONS CLOSURES MUST BE DONE WITH TAPE.
2. FILL PACKAGING REEL WITH THE QUANTITIES AS INDICATED IN THE CHART.

1. QUANTITY: 350 PCS

2. COVER TAPE PEELING FORCE:

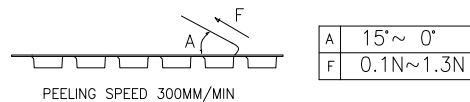

3. PART DIMENSIONS MEET EIA-481-D REQUIREMENT

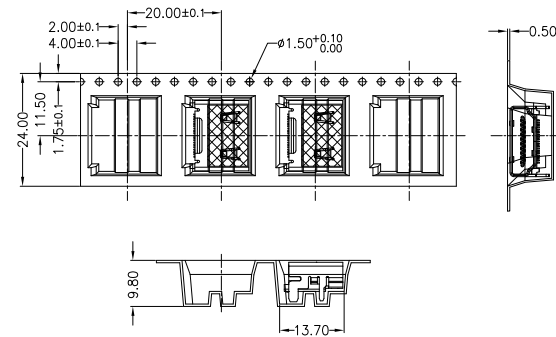
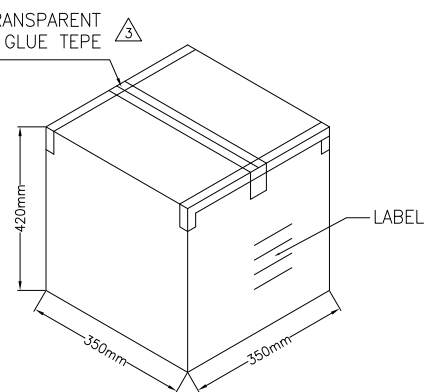
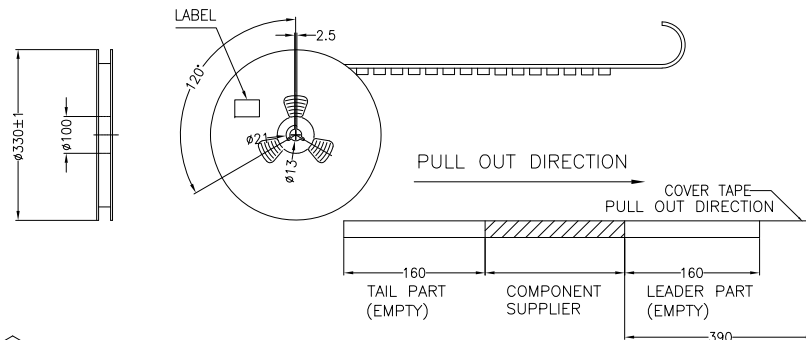
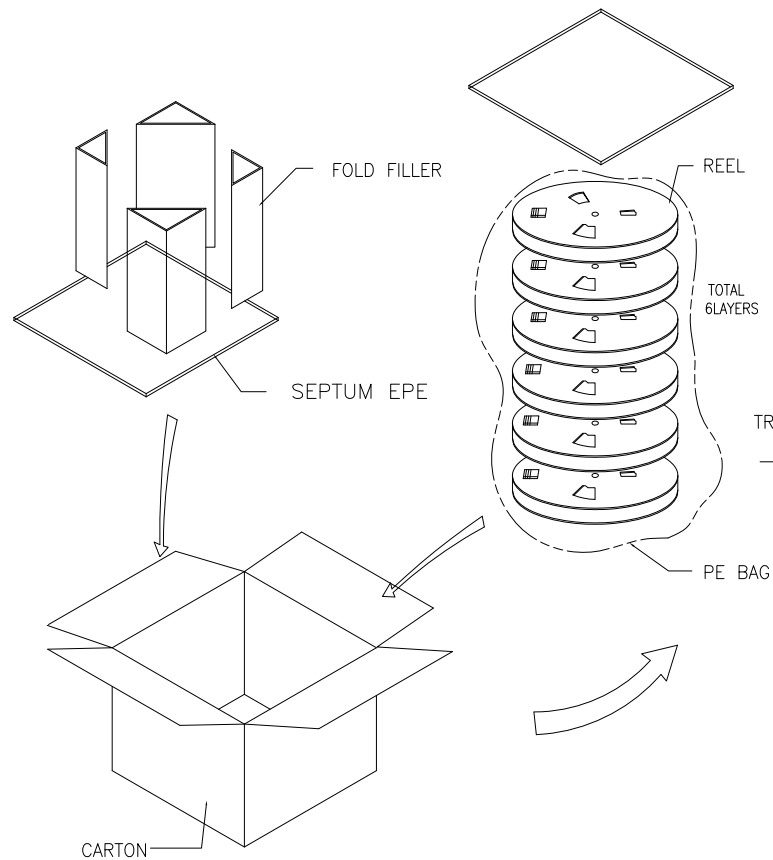

TABLE

PRODUCT P/N	PARTS PER SHIPPING CARTON	PARTS PER REEL (S.P.Q.)	TOTAL REELS PER PRIMARY CARTON
A0314-0001	3500 (PCS)	350 (PCS)	10
A0314-0008			

PRODUCT SPECIFICATION: DOC.No: SP-XXXX-XX	SCALE 1 : 1	DESIGN UNITS mm
TEST REPORT DOC.No: TR-XXXX-XX	DRAWN Mei Chen	DATE 2014/11/25
GENERAL TOLERANCES (UNLESS SPECIFIED)	CHECKED	DATE
X.XXX ± 0.10	APPROVED	DATE
X.XX ± 0.25	DWG NO. PA0314-001	PART NO. SEE TABLE
X.X ± 0.38	THIRD ANGLE PROJECTION	DWG REV. 04
ANGULAR ± 3		SHEET NO. 1 OF 1

CHT 群匯科技股份有限公司
CHIUN HUEI Technology CO., LTD.

TITLE
HDMI 2.0 A Type Receptacle SMT