

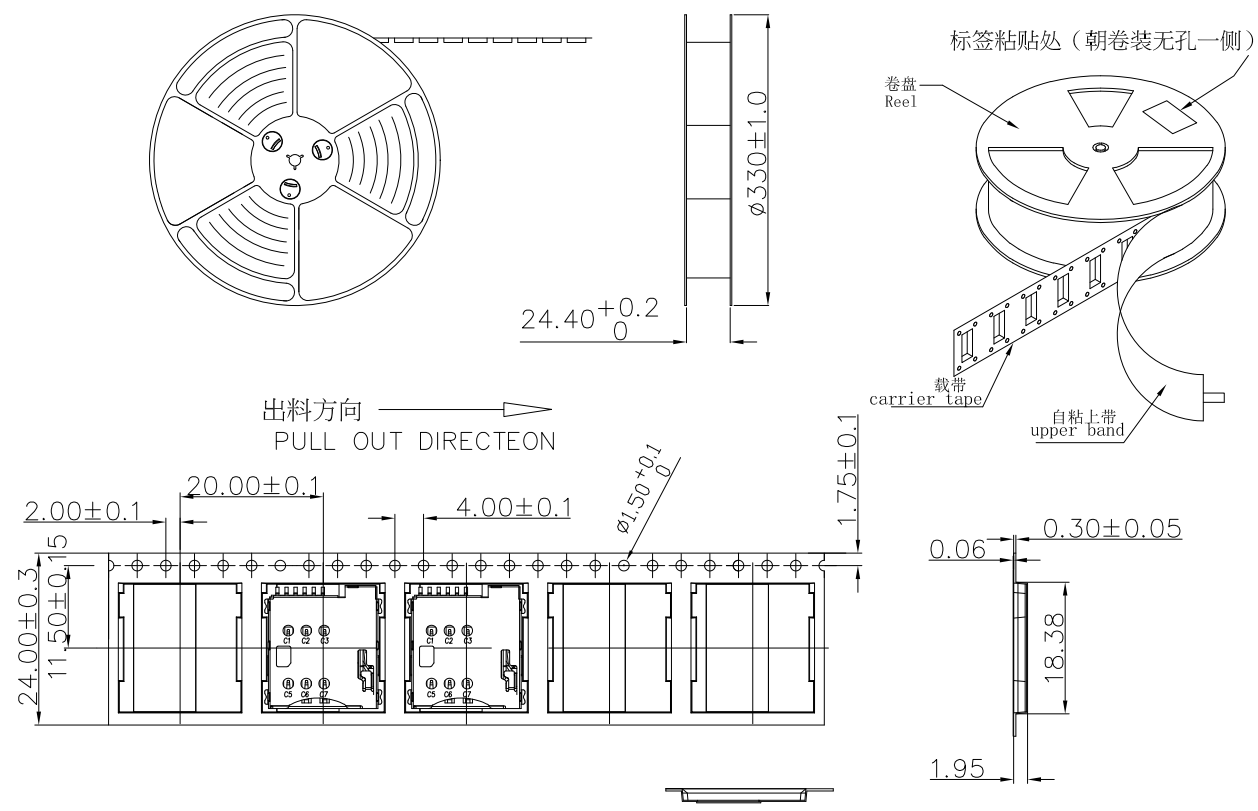

REVISION HISTORY			
REV	DESCRIPTION	Drawing	DATE
01	PROPOSAL	Allen	2022/05/24

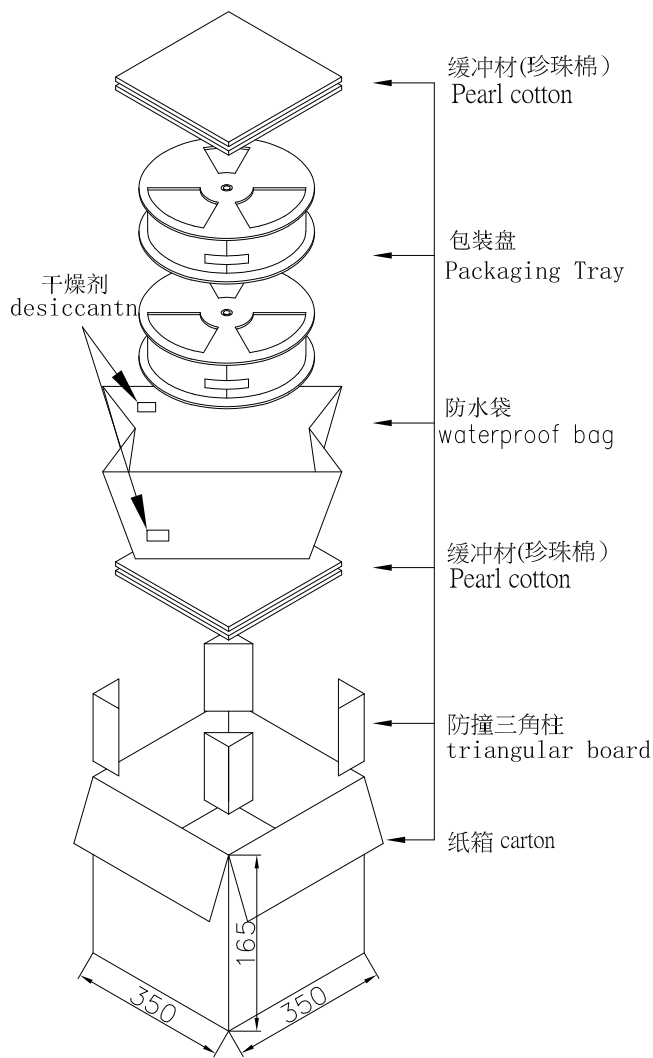

1. COVER TAPE PEELING FORCE:

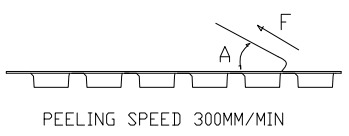

A	15°~ 0°
F	0.1N~1.3N

2. PART DIMENSIONS MEET EIA-481-D REQUIREMENT

TABLE			
PRODUCT P/N	PARTS PER SHIPPING CARTON	PARTS PER REEL (S.P.Q.)	TOTAL REELS PER SHIPPING CARTON
A0799-0001	5000(PCS)	1000(PCS)	5
PRODUCT SPECIFICATION: DDC.No: SP-AXXXX-XX		SCALE 1 : 1	DESIGN UNITS mm
TEST REPORT DDC.No: TR-AXXXX-XX		DRAWN Allen	DATE 2022/05/24
GENERAL TOLERANCES (UNLESS SPECIFIED)		CHECKED	DATE
X.XXX	± 0.10	APPROVED	DATE
X.XX	± 0.25	TITLE Micro SIM PUSH PUSH	
X.X	± 0.38		
ANGULAR ± 3°		DWG NO. PA0799-001	
THIRD ANGLE PROJECTION		PART NO. A0799-0001	DWG REV. 01
		SHEET NO. 1 OF 1	

**CHT** 群匯科技股份有限公司  
CHIUN HUEI Technology CO., LTD.