

REVISION HISTORY

REV	DESCRIPTION	Drawing	DATE
05	PROPOSAL	Mei Chen	2019/07/29

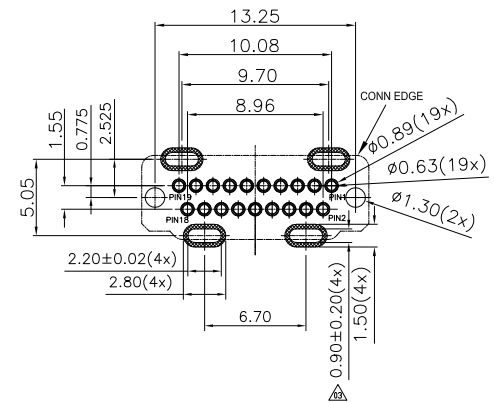

RECOMMENDED PCB LAYOUT (TOP VIEW)
GENERAL TOLERANCES: ±0.05 (t=1.6/1.2)

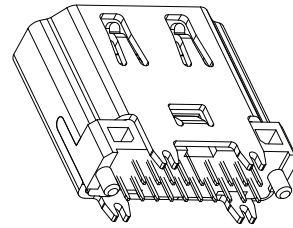
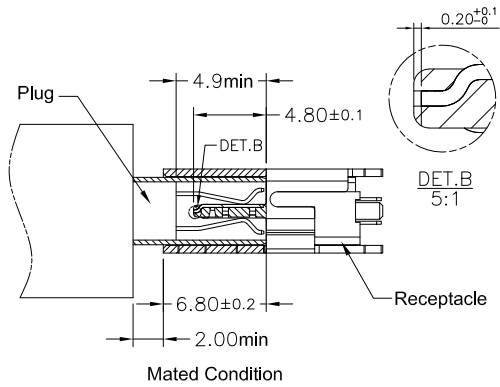
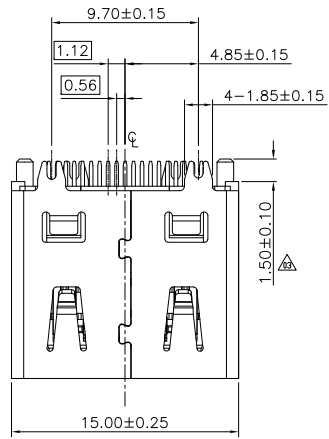
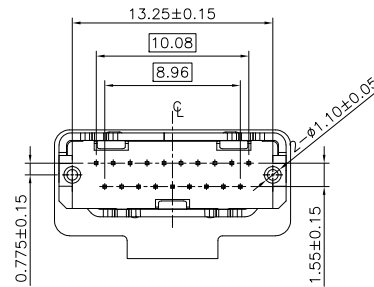
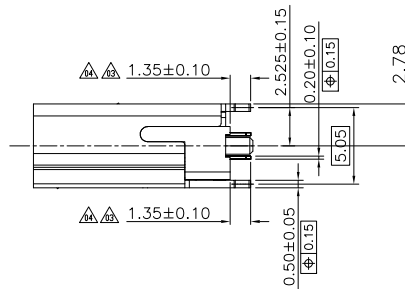
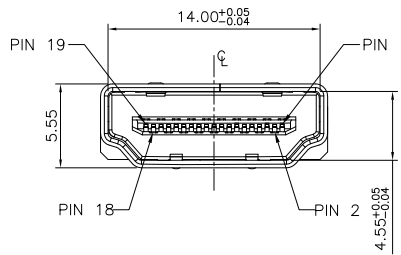

NOTE:

- MATERIAL:
 - INSULATOR: LCP,UL94V-0,Black.
 - CONTACT: C2680
 - SHELL: SK7
- FINISH:
 - TERMINAL: 50u" MIN. NICKEL PLATED OVERALL
 - CONTACT: SELECTIVE GOLD PLATED, SEE TABLE A
 - TAIL: 100u" MIN MATT-TIN PLATED
 - SHELL: 50u" MIN. NICKEL PLATED OVERALL
- PRODUCT SPECIFICATION REFER TO SP-A0670-01
- PACKAGE DRAWING REFER TO PA0670-01
- PRODUCT MUST CONFORM TO RoHS AND HALOGEN FREE REQUIREMENT

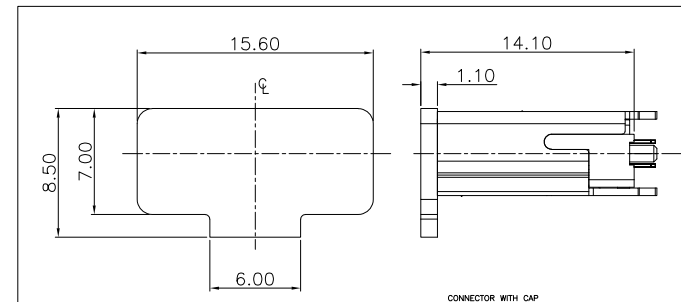
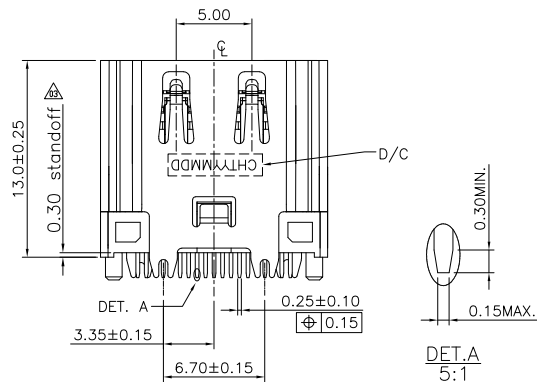

TABLE

FIH P/N	TABLE A GOLD PLATING THICKNESS
A0670-0003	Au30u
A0670-0001	G/F

PRODUCT SPECIFICATION: DDC.No: SP-AXXX-001	SCALE 1:1	DESIGN UNITS mm
TEST REPORT DDC.No: TR-AXXX-001	DRAWN Mei Chen	DATE 2018/11/30
GENERAL TOLERANCES (UNLESS SPECIFIED)	CHECKED	DATE
X.XXX ± 0.20	APPROVED	DATE
X.XX ± 0.20		
X.X ± 0.25		
ANGULAR ± 3°		
THIRD ANGLE PROJECTION	DWG NO. SA0670-001	

CHT 群匯科技股份有限公司
CHIUN HUEI Technology CO., LTD.

TITLE	HDMI AF S/T DIP TYPE H=13.0	
PART NO.	DWG REV.	SHEET NO.
SEE TABLE	05	1 OF 1

REVISION HISTORY			
REV	DESCRIPTION	Drawing	DATE
03	變更包裝數量	Linda	2019/09/23

PULL OUT DIRECTION

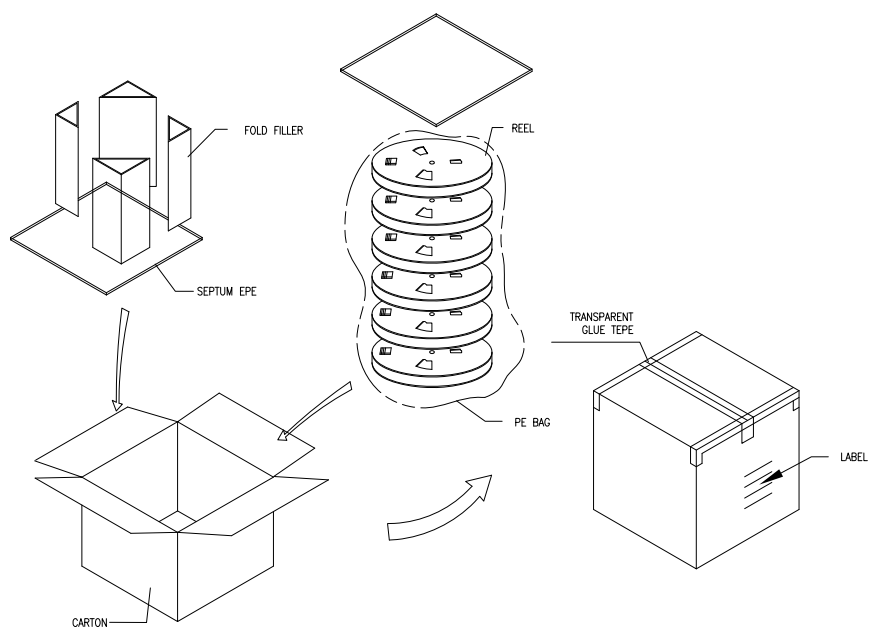
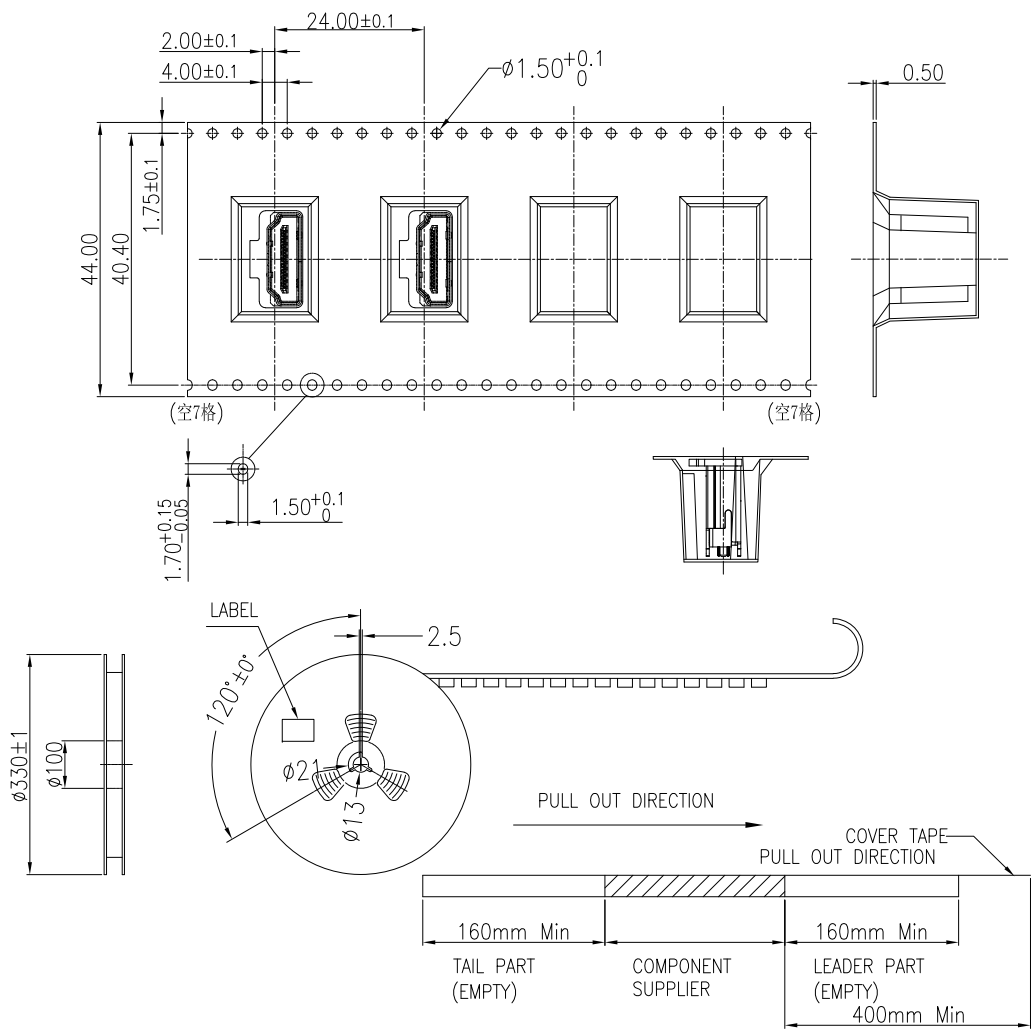

1. QUANTITY: 200 PCS
2. COVER TAPE PEELING FORCE:

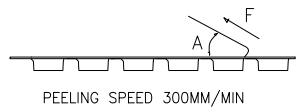

A	15°~0°
F	0.1N~1.3N

3. PART DIMENSIONS MEET EIA-481-D REQUIREMENT

PRODUCT P/N	PARTS PER SHIPPING CARTON	PARTS PER REEL	LOADED REEL PER SHIPPING CARTON
A0670-0003	1280	160	8
A0670-0006			
A0670-0001			

PRODUCT SPECIFICATION: DOC.No: SP-Axxxx-001	SCALE 1 : 1	DESIGN UNITS mm
TEST REPORT DOC.No: TR-Axxxx-001	DRAWN Linda	DATE 2019/09/23
GENERAL TOLERANCES (UNLESS SPECIFIED)	CHECKED	DATE
X.XXX ± 0.20	APPROVED	DATE
X.XX ± 0.20		
X.X ± 0.25		
ANGULAR ± 3°		
THIRD ANGLE PROJECTION	DWG NO. PA0670-001	PART NO. SEE TABLE

CHT 群匯科技股份有限公司 CHIUN HUEI Technology CO., LTD.		
TITLE HDMI AF S/T DIP TYPE H=13.0mm		
PART NO. SEE TABLE	DWG REV. 03	SHEET NO. 1 OF 1