

REVISION HISTORY			
REV	DESCRIPTION	Drawing	DATE
01	PROPOSAL	Allen	2022/01/05

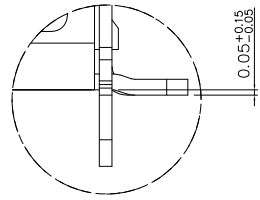
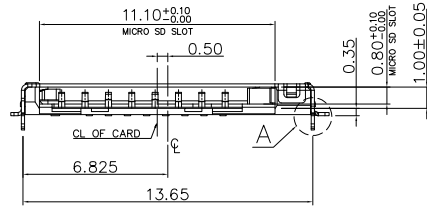
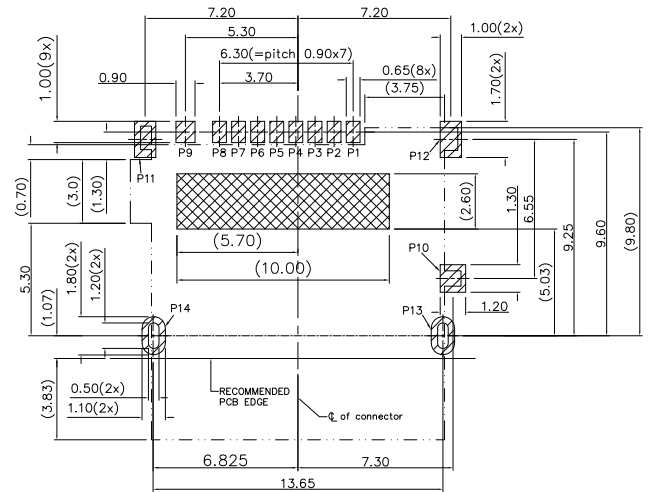
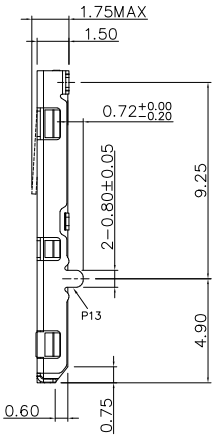
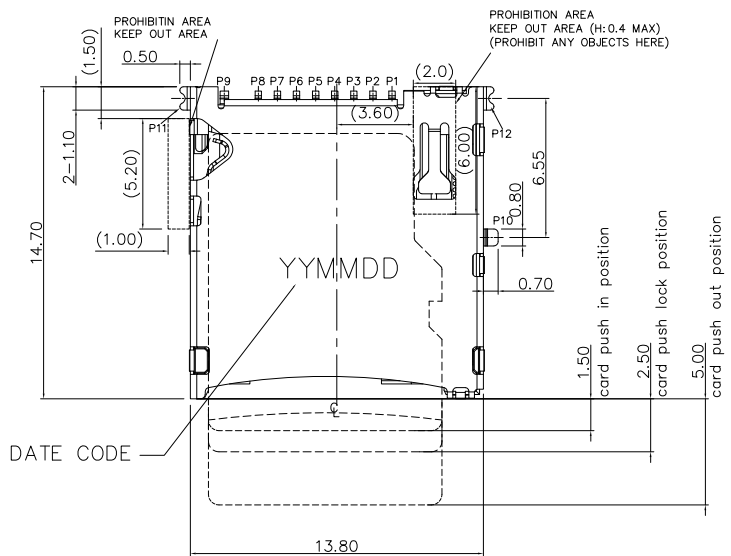
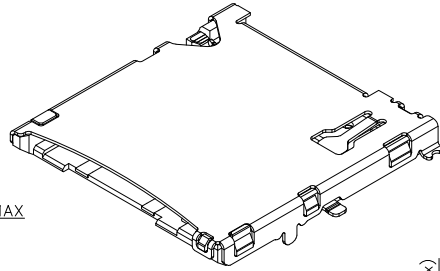
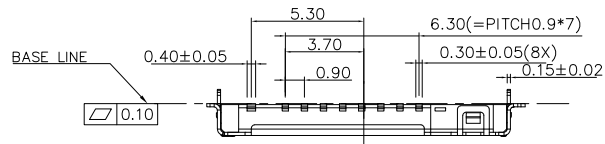

DETAIL A
SCALE 5:1

RECOMMENDED PCB LAYOUT(TOP VIEW)
GENERAL TOLERANCE: ±0.05

- PAD AREA
- NO COPPER AREA
- KEEP OUT AREA

- NOTES:
- MATERIAL:
 - 1.1 PLASTIC: LCP , UL 94V-0, COLOR: BLACK
 - 1.2 CONTACT: COPPER ALLOY (C5210)
 - 1.3 SHELL: STAINLESS STEEL (SUS304)
 - FINISH:
 - 2.1 TERMINAL: 50u" MIN. NICKEL PLATED OVERALL
 - 2.2 CONTACT: SELECTIVE GOLD PLATED, SEE TABLE A
 - 2.3 TAIL: 120u" MATT-TIN PLATED
 - 2.4 SHELL: 50u" MIN. NICKEL PLATED OVERALL
 - PRODUCT SPECIFICATION REFER TO SP-A0908-01
 - PACKAGE DRAWING REFER TO PA0908-01
 - PRODUCT MUST CONFORM TO RoHS AND HALOGEN FREE REQUIREMENT

PIN NUMBER	PIN DEFINE
PIN 1	MICRO SD_DAT2
PIN 2	MICRO SD_CD/DAT3
PIN 3	MICRO SD_CMD
PIN 4	MICRO SD_VDD
PIN 5	MICRO SD_CLK
PIN 6	MICRO SD_VSS
PIN 7	MICRO SD_DAT0
PIN 8	MICRO SD_DAT1
PIN 9	MICRO SD_CD
PIN 10	GND FOR P9 CD
PIN 11,12,13,14	GND

CARD DETECT SWITCH OPEN/CLOSE FOR MICRO SD CARD POSITION

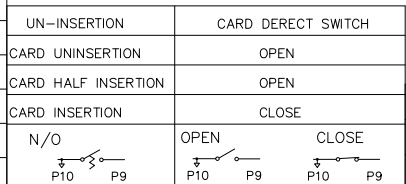

TABLE	TABLE A
CHT P/N	GOLD PLATING THICKNESS
A0908-0003	Au30u
A0908-0001	G/F

PRODUCT SPECIFICATION:	SCALE	DESIGN UNITS
DOC.No: SP-AXXXX-XX	1 : 1	mm
TEST REPORT		
DOC.No: TR-AXXXX-XX	DRAWN	DATE
GENERAL TOLERANCES (UNLESS SPECIFIED)	ALLEN	2022/01/05
X.XXX ± 0.10	CHECKED	DATE
X.XX ± 0.25	APPROVED	DATE
X.X ± 0.38		
ANGULAR ± 3°	DWG NO.	
THIRD ANGLE PROJECTION	SA0908-001	

CHT 群匯科技股份有限公司
CHIUN HUEI Technology CO., LTD.

TITLE
Micro SD Push Push Connector
Top-Mount,H=1.5

PART NO.	DWG REV.	SHEET NO.
TABLE A	01	1 OF 1

REVISION HISTORY			
REV	DESCRIPTION	Drawing	DATE
02	修改尺寸	Allen	2022/01/07

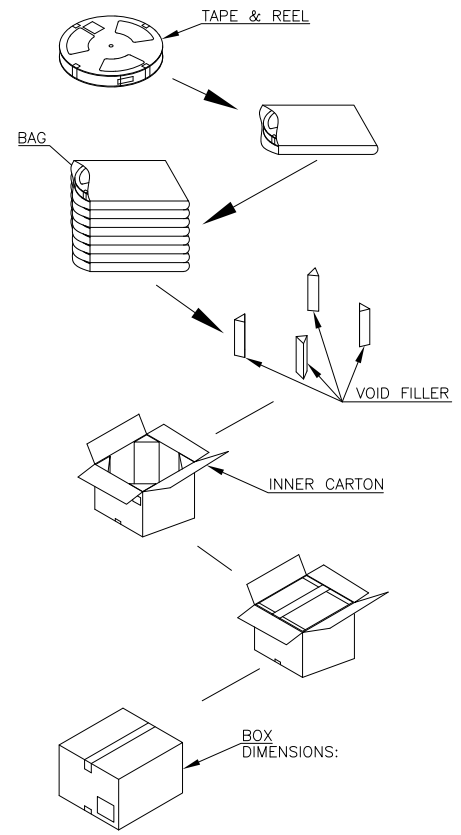
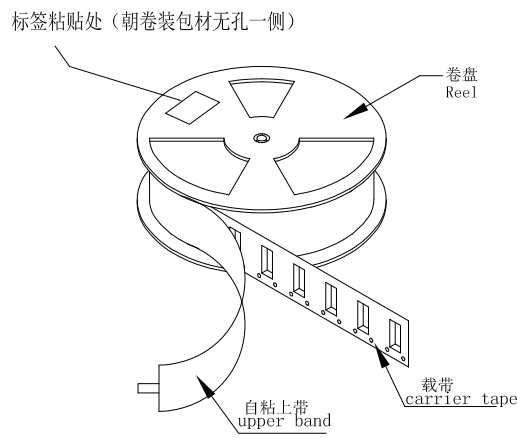
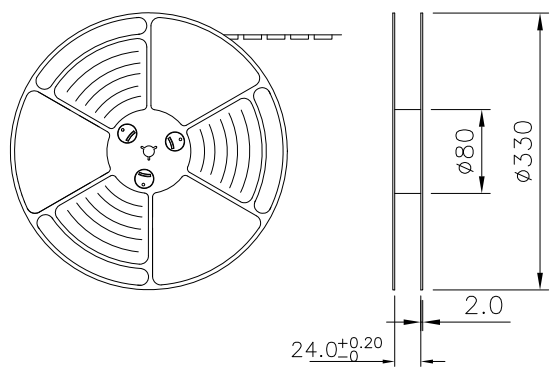
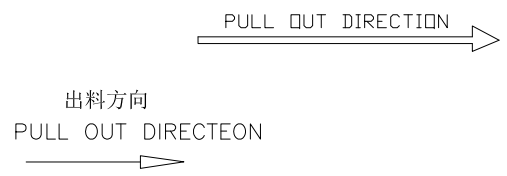
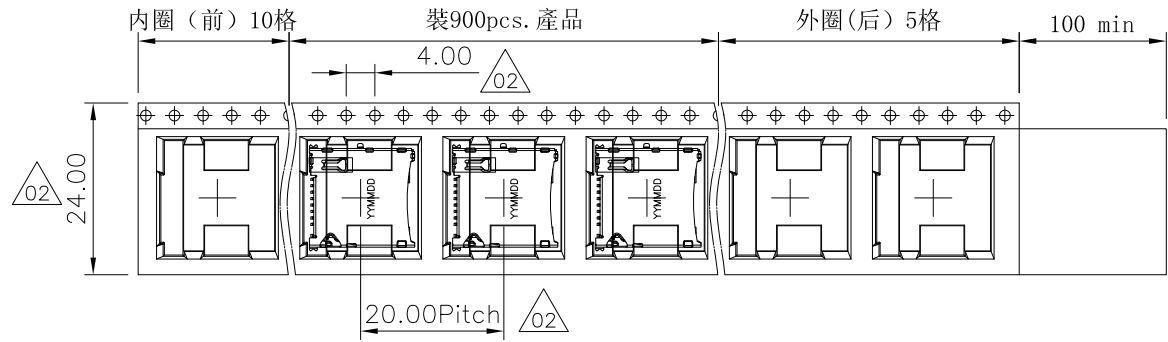

1. COVER TAPE PEELING FORCE:

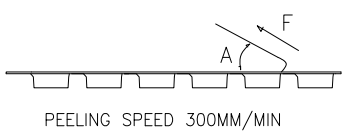

A	15° ~ 0°
F	0.1N ~ 1.3N

2. PART DIMENSIONS MEET EIA-481-D REQUIREMENT

TABLE

PRODUCT P/N	PARTS PER SHIPPING CARTON	PARTS PER REEL (S.P.Q.)	TOTAL REELS PER SHIPPING CARTON
A0908-0003	8100(PCS)	900(PCS)	9
A0908-0001			
PRODUCT SPECIFICATION: DDC No: SP-Axxxx-xx	SCALE 1 : 1	DESIGN UNITS mm	CHT 群匯科技股份有限公司 CHIUN HUEI Technology CO., LTD.
TEST REPORT DDC No: TR-Axxxx-xx	DRAWN Allen	DATE 2022/01/05	
GENERAL TOLERANCES (UNLESS SPECIFIED)	CHECKED	DATE	
X.XXX ± 0.10 X.XX ± 0.25 X.X ± 0.38	APPROVED	DATE	
ANGULAR ± 3°	DWG NO. PA0908-001	PART NO. SEE TABLE	TITLE Micro SD Push Push Connector Top-Mount, H=1.5
THIRD ANGLE PROJECTION	DWG REV. 02	SHEET NO. 1 OF 1	