

REVISION HISTORY			
REV	DESCRIPTION	Drawing	DATE
24	增加壓料孔	Allen	2021/10/12

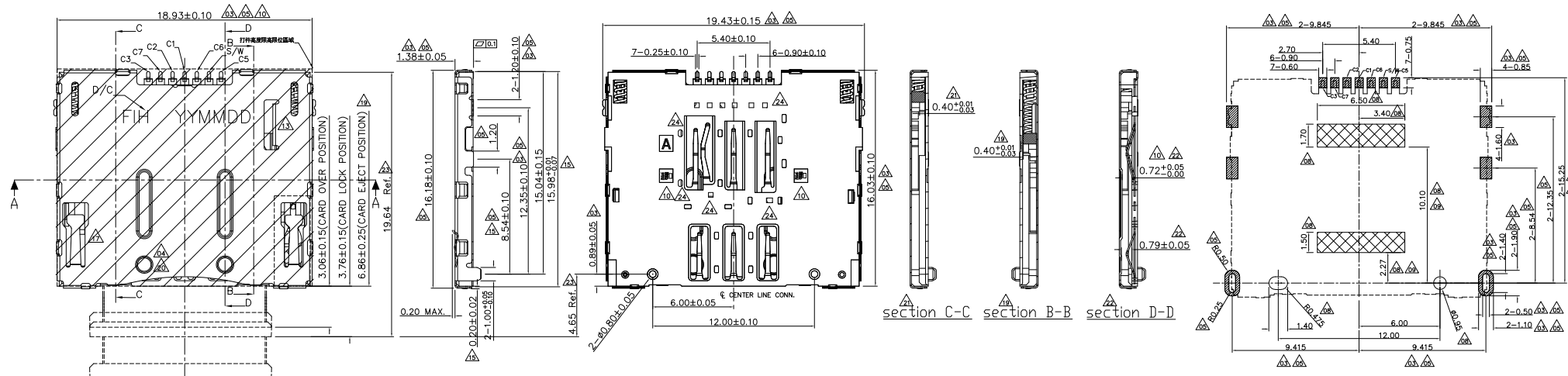

RECOMMENDED P.C.B LAYOUT(TOP VIEW)
(General Tolerance±0.05)

- ▨ PAD AREA
- ▨ NO TRACE,NO TEST POINT
- ▨ NO VIA HOLE,NO GROUND AREA

NOTES:

1. MATERIAL:
 - 1.1 HOUSING: LCP S475 BLACK , UL 94V-0
 - 1.2 CONTACT: C5210
 - 1.3 SHELL: SUS304
 - 1.4 SPRING: SWPB
 - 1.5 CRANK: SUS304
 - 1.6 SLIDER: PA4T BLACK , UL 94V-0
2. FINISH:
 - 2.1 CONTACT:
 - TERMINAL : 50u" MIN. NICKEL PLATED OVERALL.
 - CONTACT AREA : GOLD FLASH.
 - SOLDERTAIL : 100u" MATTE-TIN PLATED.
 - 2.2 SHELL: PLATED Ni 50u" Min.
 - 2.3 SPRING: PLATED Ni 50u" Min.
3. Tray在Lock位置左右高低差 0.1mm Max.
4. 連接器X, Y軸 IR 平面度 0.1mm Max.

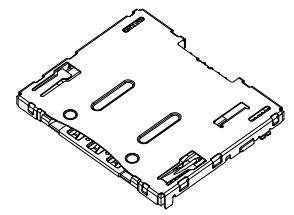
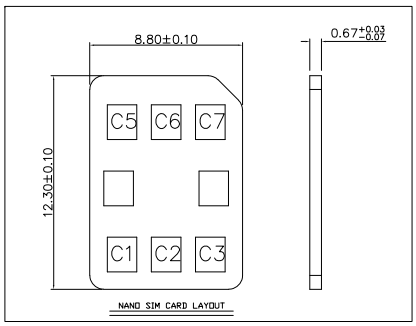
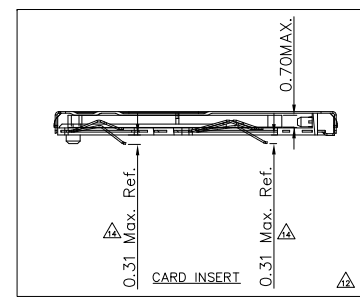
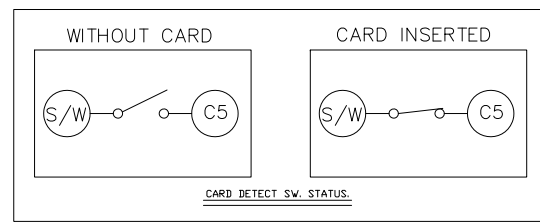

Pin Define	
Connector terminal NO.	Pin Description
C 1	VCC
C 2	RST
C 3	CLK
C 5	GND
C 6	VPP
C 7	I/O
S/W	DETECT SWITCH

PRODUCT SPECIFICATION: DOC.No: SP-Axxxx-xx	SCALE 1 : 1	DESIGN UNITS mm
TEST REPORT DOC.No: TR-Axxxx-xx	DRAWN Allen	DATE 2020/10/14
GENERAL TOLERANCES (UNLESS SPECIFIED)	CHECKED	DATE
X.XXX ± 0.20	APPROVED	DATE
X.XX ± 0.20		
X.X ± 0.25		
ANGULAR ± 3°	DWG NO. SA0857-001	PART NO. A0857-0001
THIRD ANGLE PROJECTION		DWG REV. 24

FULLINHOPE Technology, LTD.		
TITLE NANO SIM PUSH-PUSH TRAY, H1.38		
PART NO. A0857-0001	DWG REV. 24	SHEET NO. 1 OF 1

REVISION HISTORY			
REV	DESCRIPTION	Drawing	DATE
04	修改圖形凸包位置	Allen	2021/07/07

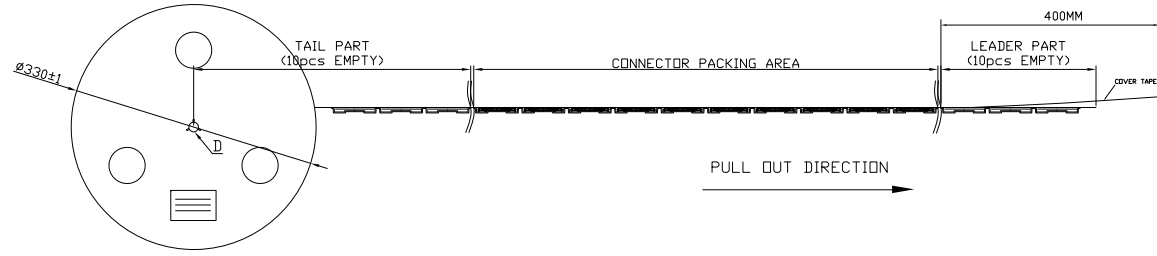
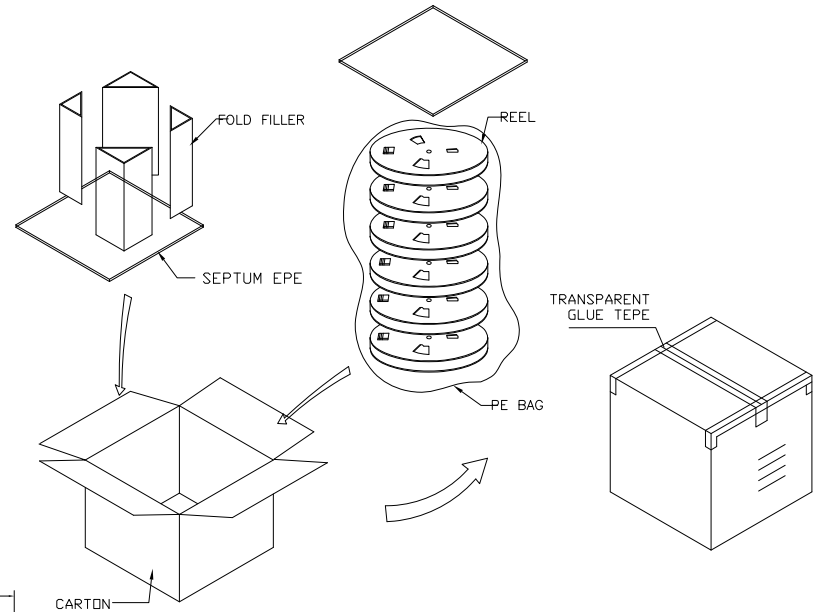
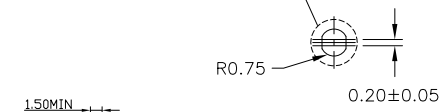
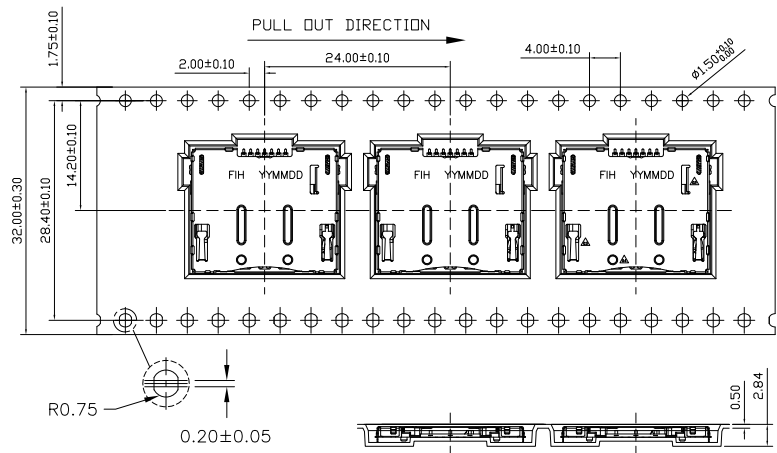

1. COVER TAPE PEELING FORCE:

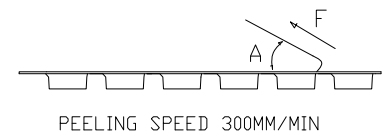

A	15°~ 0°
F	0.1N~1.3N

2. PART DIMENSIONS MEET EIA-481-D REQUIREMENT

TABLE

PRODUCT P/N	PARTS PER SHIPPING CARTON	PARTS PER REEL (S.P.Q.)	TOTAL REELS PER SHIPPING CARTON
A0857-0001	5400(PCS)	900(PCS)	6

PRODUCT SPECIFICATION: DOC.No: SP-AXXXX-001	SCALE 1 : 1	DESIGN UNITS mm	FULLINHOPE Technology, LTD.	
TEST REPORT DOC.No: TR-AXXXX-001	DRAWN Allen	DATE 2021/01/21		
GENERAL TOLERANCES (UNLESS SPECIFIED)	CHECKED	DATE		
X.XXX ± 0.20	APPROVED	DATE		
X.XX ± 0.20				
X.X ± 0.25				
ANGULAR ± 3				
THIRD ANGLE PROJECTION	DWG NO. PA0857-001	PART NO. A0857-0001	DWG REV. 04	SHEET NO. 1 OF 1