

REV	DESCRIPTION	Drawing	DATE
13	修改膠芯地料,取消SW端子加強肋	Mei Chen	2019/09/17

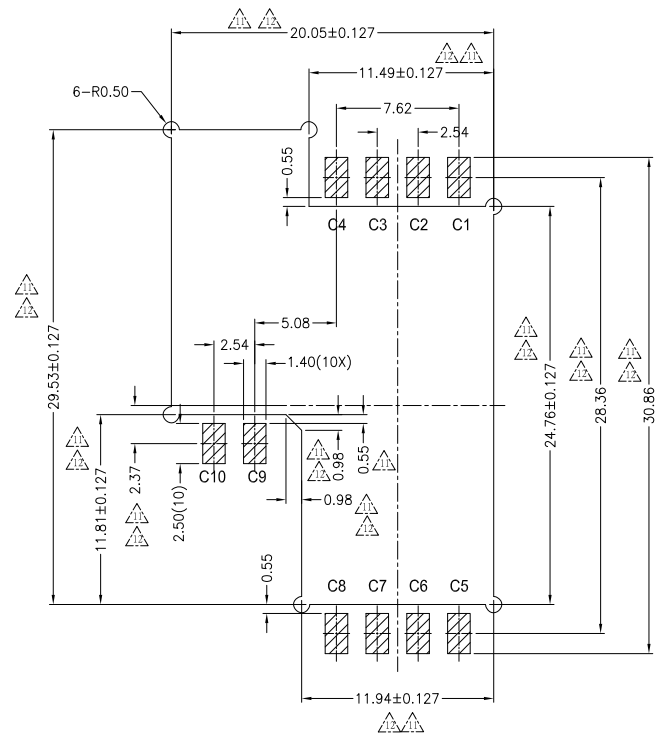

RECOMMENDED PCB LAYOUT (TOP VIEW)  
GENERAL TOLERANCES: ±0.05 (t=0.6)

- NOTE:
- MATERIAL:
    - INSULATOR: LCP+30%G.F,UL94V-0,Black
    - CONTACT: C5191
  - FINISH:
    - TERMINAL: 40μ" MIN. NICKEL PLATED OVERALL
    - CONTACT: SELECTIVE GOLD PLATED, SEE TABLE A
    - TAIL: 100μ" MIN MATT-TIN PLATED
  - PRODUCT SPECIFICATION REFER TO SP-A0690-01
  - PACKAGE DRAWING REFER TO PA0690-01
  - PRODUCT MUST CONFORM TO RoHS AND HALOGEN FREE REQUIREMENT
  - MECHANICAL CHARACTERISTIC
    - Contact Force: 0.2Nf~0.6Nf.
    - Durability: 100,000 Cycles.
  - ELECTRICAL CHARACTERISTIC
    - Current Rating: 10uA Min, 1.0A Max.
    - Voltage Rating: 30V AC.
    - Contact Resistance: 100m Ohm Max.
    - Insulation Resistance: 1000M Ohm Min
    - Dielectric Withstanding Voltage: 500V AC Min
  - TEMPERATURE
    - Operating Temperature: -40°C~+85°C
    - Storage Temperature: -60°C~+105°C

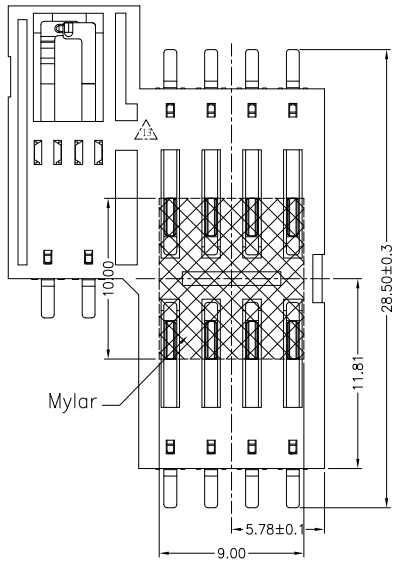
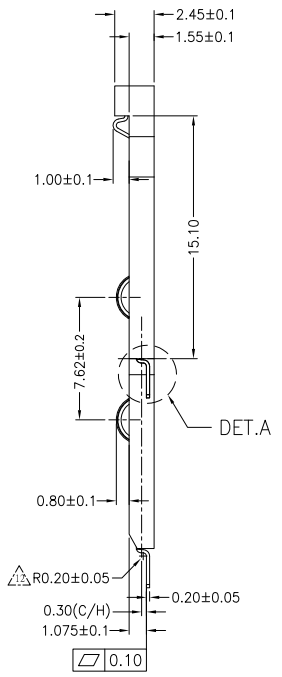
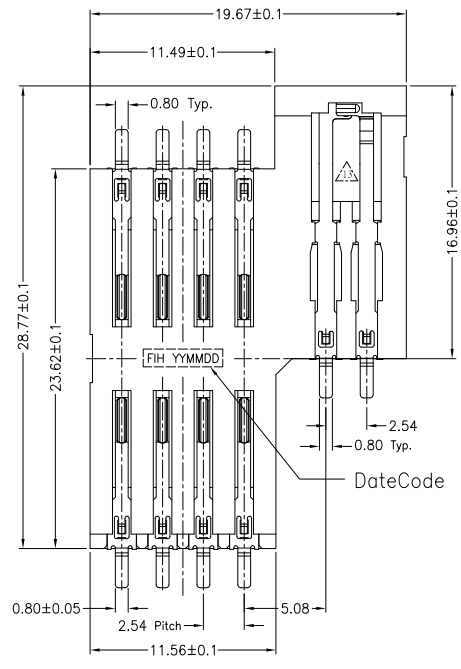
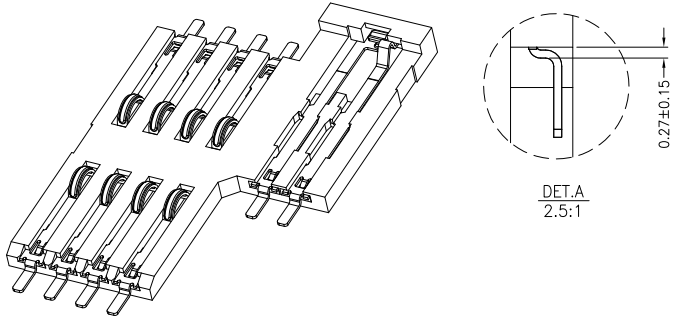

Contact Number	Signal Name
PIN C1	VCC
PIN C2	RST
PIN C3	CLK
PIN C4	C4
PIN C5	GND
PIN C6	VPP
PIN C7	IO
PIN C8	C8
PIN C9	SW-CD
PIN C10	SW-CD-GND

FIH P/N	TABLE A GOLD PLATING THICKNESS
A0690-0003	Au30u
A0690-0001	G/F

PRODUCT SPECIFICATION: DDC.No: SP-Axxxx-xx	SCALE 1:1	DESIGN UNITS mm
TEST REPORT DDC.No: TR-Axxxx-xx	DRAWN Mei Chen	DATE 2019/03/06
GENERAL TOLERANCES (UNLESS SPECIFIED)	CHECKED	DATE
X.XXX ± 0.10	APPROVED	DATE
X.XX ± 0.25	DWG NO. SA0690-001	
X.X ± 0.38		
ANGULAR ± 3°		
THIRD ANGLE PROJECTION		

**CHT** 群匯科技股份有限公司  
CHIUN HUEI Technology CO., LTD.

TITLE  
SMART CARD SOCKET  
PRODUCT H=1.075

PART NO.	DWG REV.	SHEET NO.
TABLE A	13	1 OF 1

REVISION HISTORY			
REV	DESCRIPTION	Drawing	DATE
04	成品修改外型	Mei Chen	2019/09/17

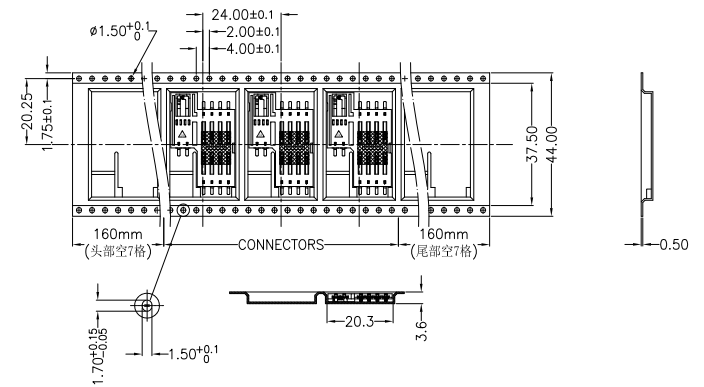
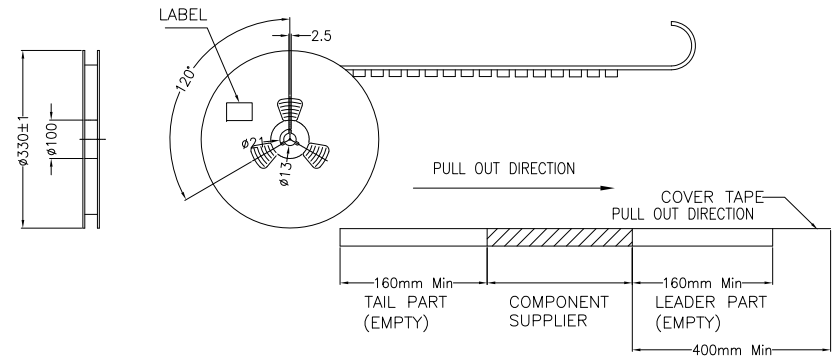
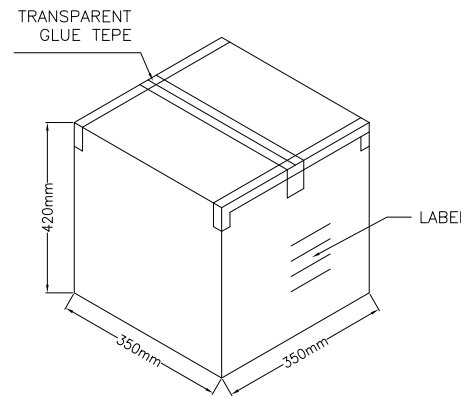
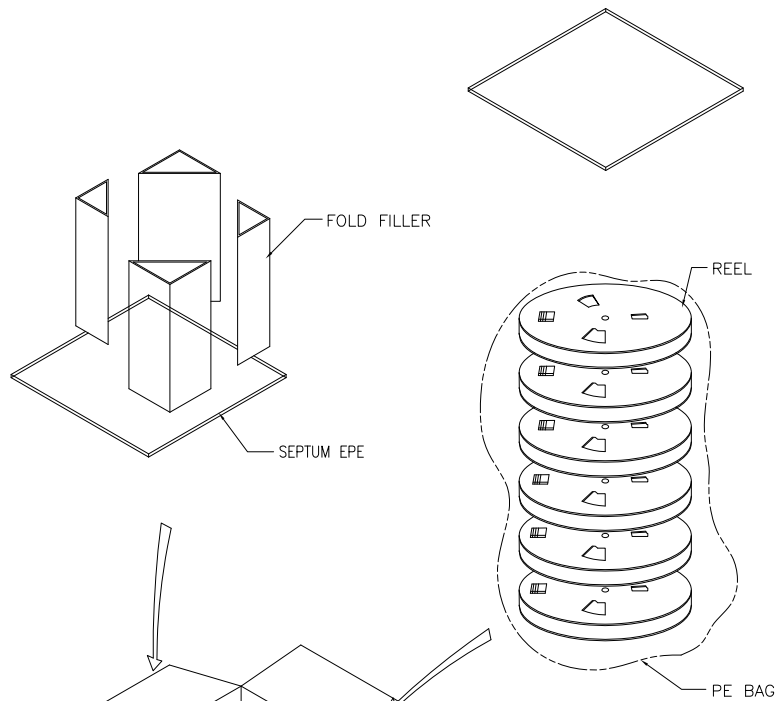

1. COVER TAPE PEELING FORCE:

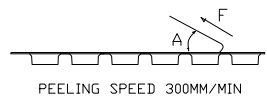

A	15°~ 0°
F	0.1N~1.3N

2. PART DIMENSIONS MEET EIA-481-2-A REQUIREMENT

TABLE

PRODUCT P/N	PARTS PER SHIPPING CARTON	PARTS PER REEL	LOADED REEL PER SHIPPING CARTON
A0690-0003	6400	800	8
A0690-0001			

PRODUCT SPECIFICATION: DDC.No: SP-AXXXX-XX		SCALE 1 : 1	DESIGN UNITS mm	<b>CHT</b> 群匯科技股份有限公司 CHIUN HUEI Technology CO., LTD.
TEST REPORT DDC.No: TR-AXXXX-XX		DRAWN Mei Chen	DATE 2019/03/06	
GENERAL TOLERANCES (UNLESS SPECIFIED)		CHECKED	DATE	
ANGULAR ± 3°		APPROVED	DATE	
THIRD ANGLE PROJECTION		DWG NO. PA0690-001	PART NO. SEE TABLE	DWG REV. 04
				SHEET NO. 1 OF 1