

REVISION HISTORY			
REV	DESCRIPTION	Drawing	DATE
A	RELEASE	Linda	2019/06/28

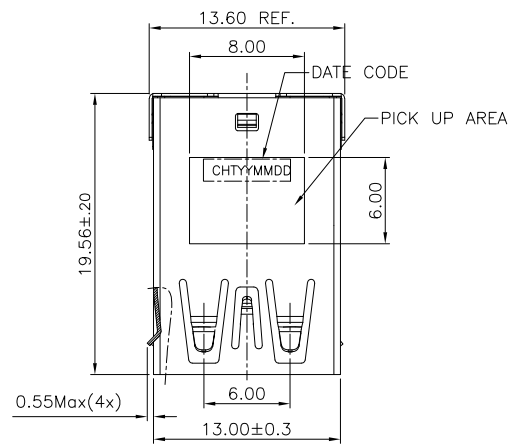

NOTE:  
 1. MATERIAL:  
 1.1 INSULATOR: PA9T, UL94 V-0, Black  
 1.2 CONTACT: 4PIN:C5191, 5PIN:C2680  
 1.3 Front/Back/Middle Shell: SUS201  
 2. FINISH:  
 2.1 TERMINAL: 50u" MIN. NICKEL PLATED OVERALL  
 2.2 CONTACT: SELECTIVE GOLD PLATED, SEE TABLE  
 2.3 TAIL: 100u" MATT-TIN PLATED  
 2.4 SHELL: 80u" MIN. NICKEL PLATED OVERALL  
 3. PRODUCT SPECIFICATION REFER TO SP-A0647-01  
 4. PACKAGE DRAWING REFER TO PA0647-01  
 5. DATE CODE: XX (YEAR), XX (MONTH), XX (DATE), Laser  
 6. PRODUCT MUST CONFORM TO RoHS AND HALOGEN FREE REQUIREMENT

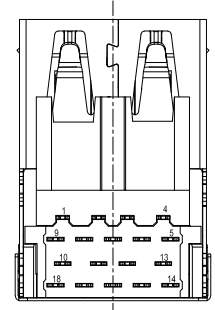
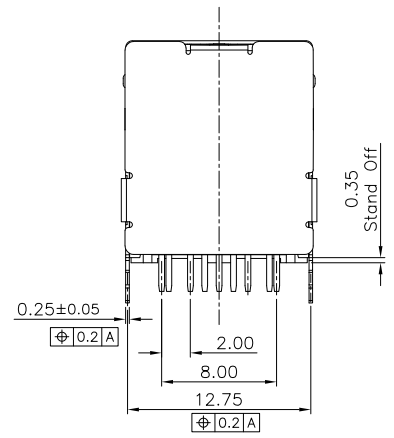
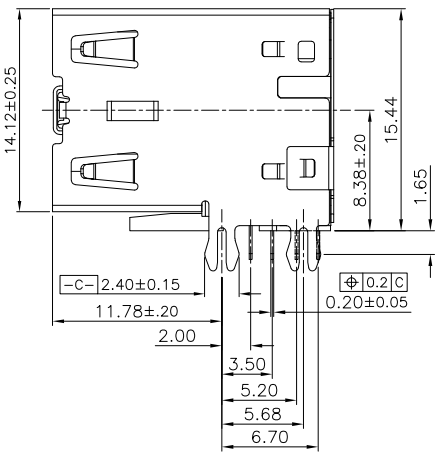
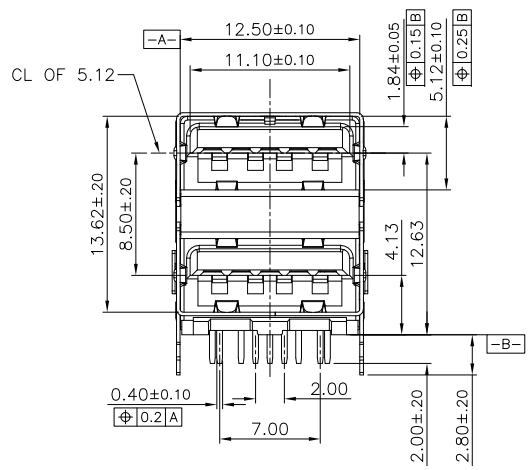
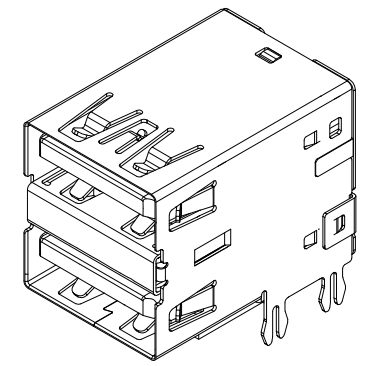

USB3.0 CONTACT PIN					
PIN NO.	1/10	2/11	3/12	4/13	Shell
NAME	VBUS	D-	D+	GND	Shield
PIN NO.	5/14	6/15	7/16	8/17	9/18
NAME	StdA-SSR-	StdA-SSR+	GND-DRAIN	StdA-SST-	StdA-SST+

TABLE

FIH P/N	GOLD THICKNESS
A0647-0006	15u"
A0647-0004	30u"pbNi+2u" Au
A0647-0003	30u"
A0647-0001	G/F

PRODUCT SPECIFICATION: DOC.No: SP-A0647-01	SCALE 1 : 1	DESIGN UNITS mm
TEST REPORT DOC.No: TR-A0647-01	DRAWN Linda	DATE 2019/06/28
GENERAL TOLERANCES (UNLESS SPECIFIED)	CHECKED	DATE
	APPROVED	DATE
	DWG NO. SA0647-001	

**CHT** 群匯科技股份有限公司  
 CHUIN HUEI Technology CO., LTD.

TITLE DUAL STACK USB 3.0 GEN 1 A TYPE RECEPTACLE STD RA DIP C/H=8.38mm		
PART NO. SEE TABLE	DWG REV. A	SHEET NO. 1 OF 2

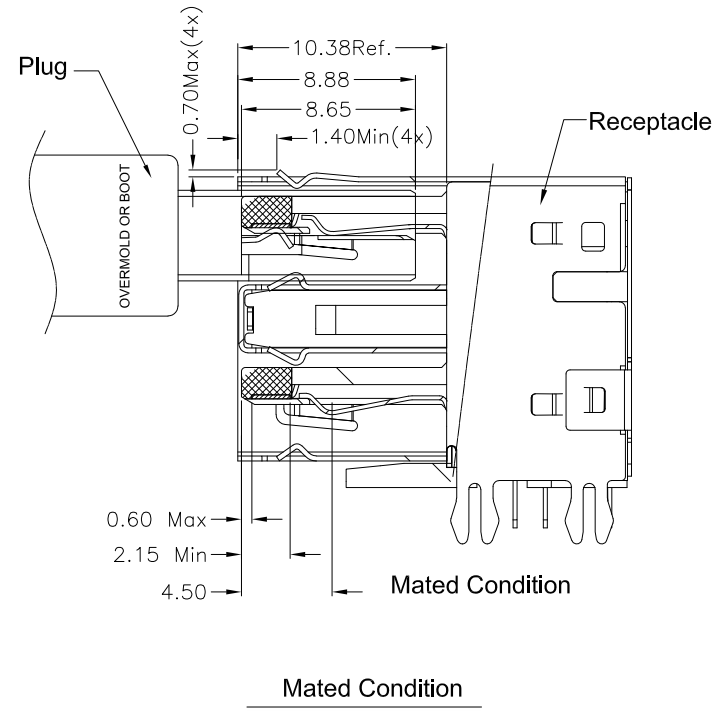
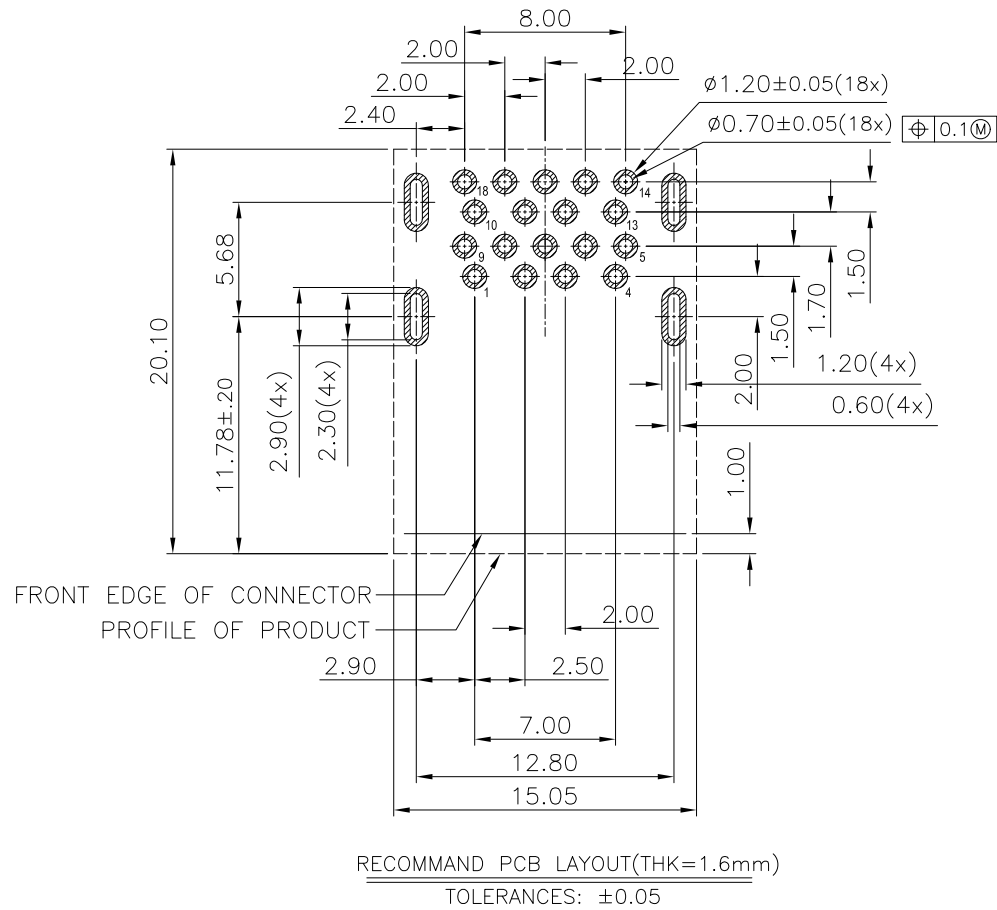

PRODUCT SPECIFICATION: DOC.No: SP-AXXX-XX		SCALE 1 : 1	DESIGN UNITS mm	<b>CHT</b> 群匯科技股份有限公司 CHIUN HUEI Technology CO., LTD.
TEST REPORT DOC.No: TR-AXXX-XX		DRAWN Linda	DATE 2019/06/28	
GENERAL TOLERANCES (UNLESS SPECIFIED)		CHECKED	DATE	TITLE DUAL STACK USB 3.0 GEN 1 A TYPE RECEPTACLE STD RA DIP C/H=8.38mm
X.XXX	± 0.15	APPROVED	DATE	
X.XX	± 0.25			
X.X	± 0.35			
ANGULAR ± 3°		DWG NO. SA0647-001	PART NO. SEE TABLE	DWG REV. A
THIRD ANGLE PROJECTION				SHEET NO. 2 OF 2

REVISION HISTORY			
REV	DESCRIPTION	Drawing	DATE
A	RELEASE	Linda	2019/06/28

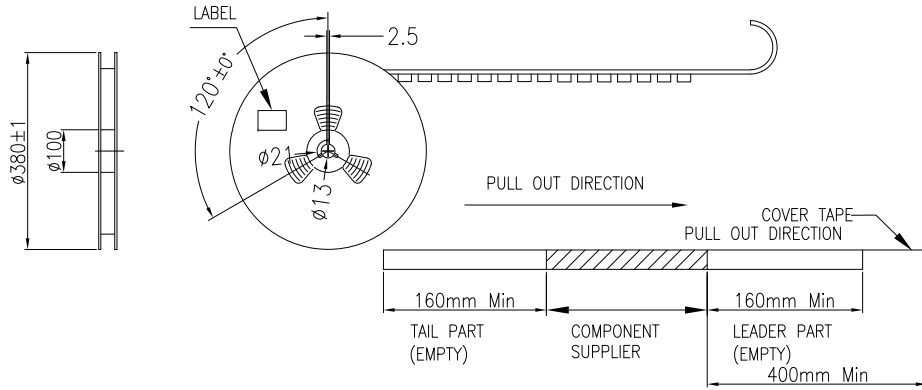
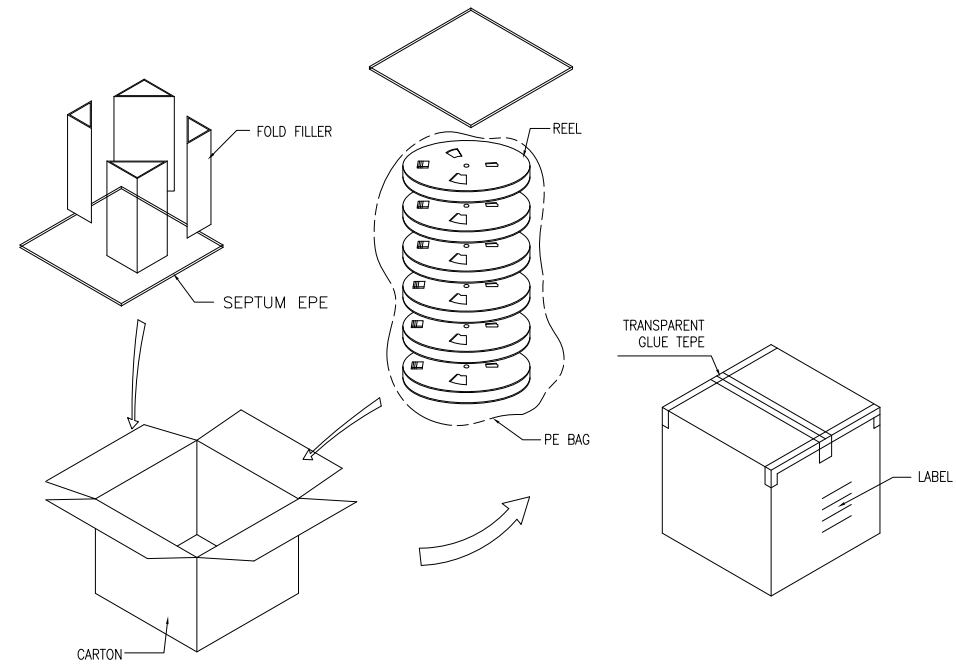
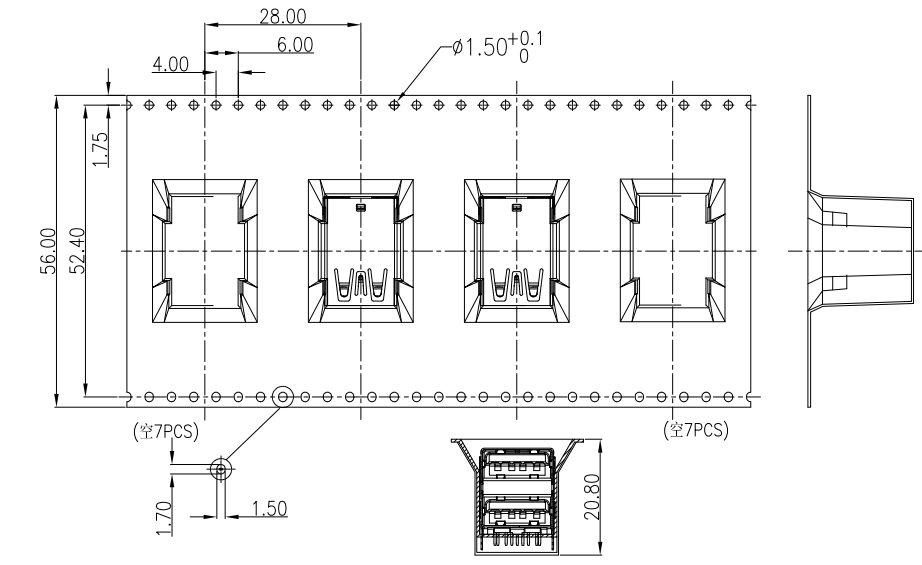

1. COVER TAPE PEELING FORCE:

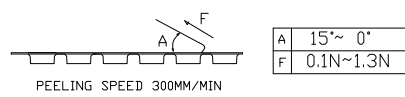

2. PART DIMENSIONS MEET EIA-481-2-A REQUIREMENT

TABLE

PRODUCT P/N	PARTS PER SHIPPING CARTON	PARTS PER REEL	LOADED REEL PER SHIPPING CARTON
A0647-0006	960	160	6
A0647-0004			
A0647-0003			
A0647-0001			

PRODUCT SPECIFICATION: DOC.No: SP-Axxxx-xx	SCALE 1 : 1	DESIGN UNITS mm	<b>CHT</b> 群匯科技股份有限公司 CHIUN HUEI Technology CO., LTD.	
TEST REPORT DOC.No: TR-Axxxx-xx	DRAWN ALLEN	DATE 2019/06/28		
GENERAL TOLERANCES (UNLESS SPECIFIED)	CHECKED	DATE	TITLE DUAL STACK USB 3.0 GEN 1 A TYPE RECEPTACLE STD RA DIP C/H=8.38 mm	
X.XXX ± 0.20	APPROVED	DATE		
X.XX ± 0.20 X.X ± 0.25 ANGULAR ± 3°	DWG NO. PA0647-001	PART NO. SEE TABLE		