

REVISION HISTORY			
REV	DESCRIPTION	Drawing	DATE
F	修改限制說明及增加尺寸	Allen	2020/09/16

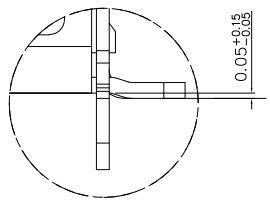
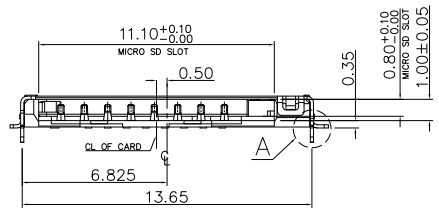
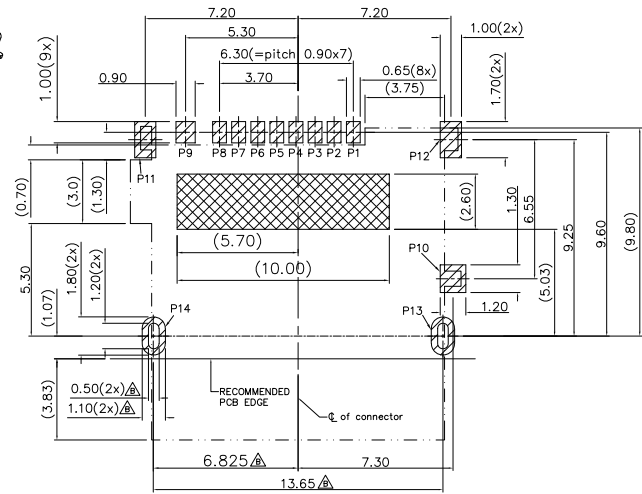
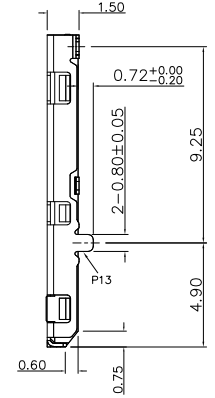
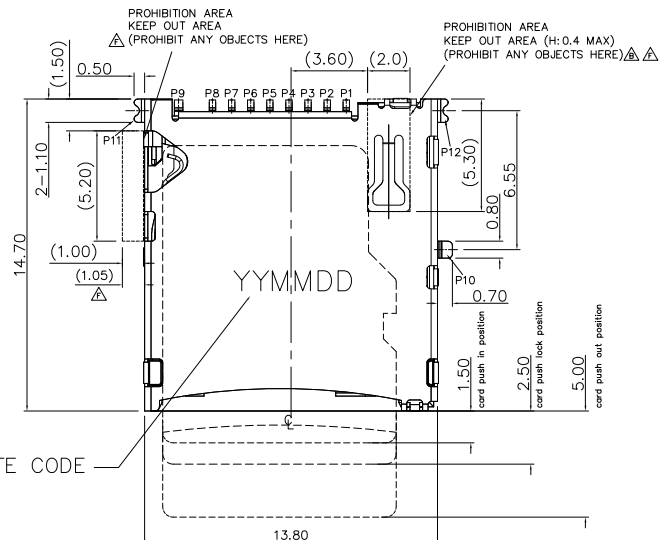
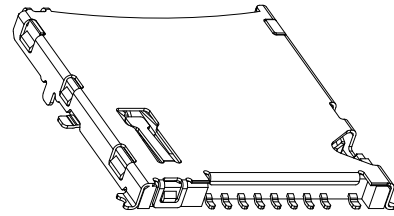
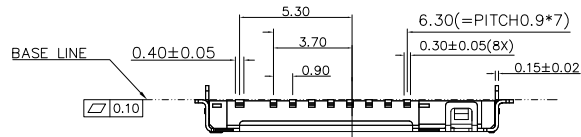

DETAIL A  
SCALE 5:1

RECOMMENDED PCB LAYOUT(TOP VIEW)  
GENERAL TOLERANCE: ±0.05

- PAD AREA
- VIA AND TRACE KEEP-OUT AREA
- OTHER COMPONENT KEEP-OUT AREA

- NOTES:
- MATERIAL:
    - 1.1 PLASTIC: LCP , UL 94V-0, COLOR: BLACK
    - 1.2 CONTACT: COPPER ALLOY (C5210)
    - 1.3 SHELL: STAINLESS STEEL (SUS304)
  - FINISH:
    - 2.1 TERMINAL: 50u" MIN. NICKEL PLATED OVERALL
    - 2.2 CONTACT: SELECTIVE GOLD PLATED, SEE TABLE A
    - 2.3 TAIL: 120u" MATT-TIN PLATED
    - 2.4 SHELL: 50u" MIN. NICKEL PLATED OVERALL
  - PRODUCT SPECIFICATION REFER TO SP-A0818-01
  - PACKAGE DRAWING REFER TO PA0818-01
  - PRODUCT MUST CONFORM TO RoHS AND HALOGEN FREE REQUIREMENT

PIN NUMBER	PIN DEFINE
PIN 1	MICRO_SD_DAT2
PIN 2	MICRO_SD_CD/DAT3
PIN 3	MICRO_SD_CMD
PIN 4	MICRO_SD_VDD
PIN 5	MICRO_SD_CLK
PIN 6	MICRO_SD_VSS
PIN 7	MICRO_SD_DAT0
PIN 8	MICRO_SD_DAT1
PIN 9	MICRO_SD_CD
PIN 10	GND FOR P9 CD
PIN 11,12,13,14	GND

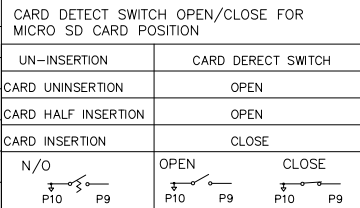

TABLE

FIH P/N	TABLE A GOLD PLATING THICKNESS
A0818-0003	Au30u
A0818-0001	G/F

PRODUCT SPECIFICATION: DOC.No: SP-A0818-01 TEST REPORT DOC.No: TR-A0818-01 GENERAL TOLERANCES (UNLESS SPECIFIED)	SCALE 1 : 1	DESIGN UNITS mm
X.XXX ± 0.10 X.XX ± 0.25 X.X ± 0.38 ANGULAR ± 3°	DRAWN ALLEN	DATE 2020/02/26
	CHECKED	DATE
	APPROVED	DATE
	DWG NO. SA0818-001	

**CHT** 群匯科技股份有限公司  
CHIUN HUEI Technology CO., LTD.

TITLE  
Micro SD Push Push Connector  
Top-Mount,H=1.5

PART NO. TABLE A	DWG REV. F	SHEET NO. 1 OF 1
---------------------	---------------	---------------------

REVISION HISTORY			
REV	DESCRIPTION	Drawing	DATE
B	變更包材形狀	Allen	2020/07/15

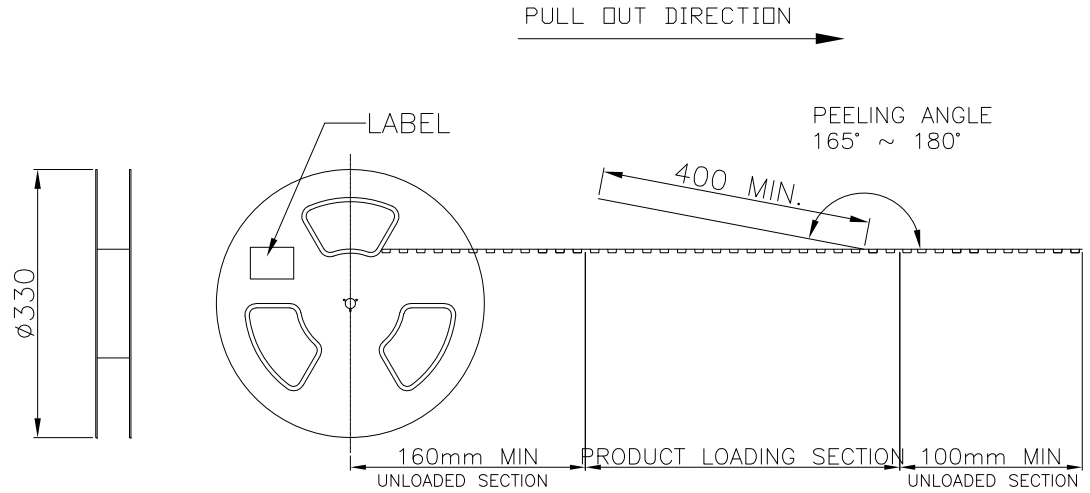
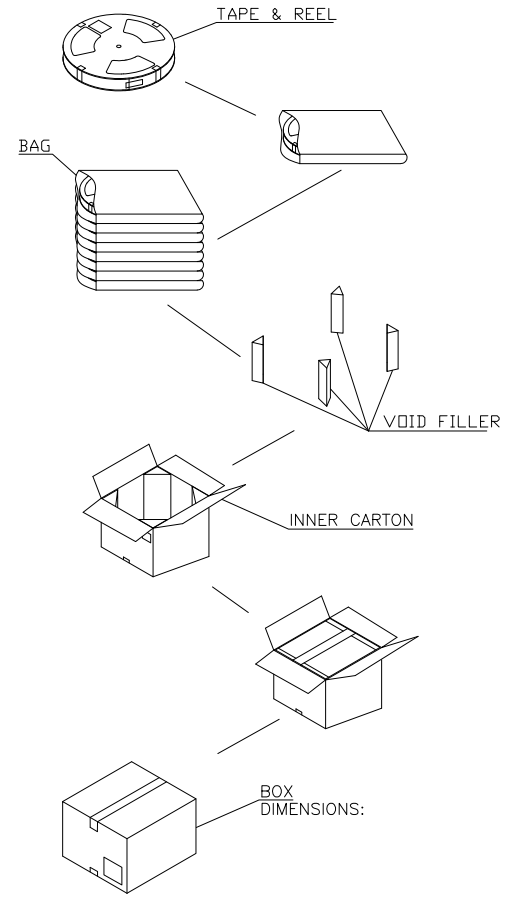
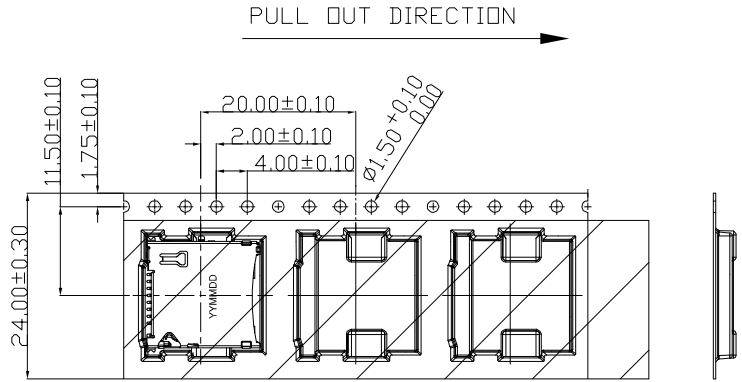

1. QUANTITY: 900PCS
2. COVER TAPE PEELING FORCE:
 

A	15° ~ 0°
F	0.1N ~ 1.3N

PEELING SPEED 300MM/MIN
3. PART DIMENSIONS MEET EIA-481-D REQUIREMENT

TABLE

PRODUCT P/N	PARTS PER SHIPPING CARTON	PARTS PER REEL (S.P.Q.)	TOTAL REELS PER SHIPPING CARTON
A0818-0003	8100(PCS)	900(PCS)	9
A0818-0001			
PRODUCT SPECIFICATION: DDC.No: SF-AXXXX-XX TEST REPORT DDC.No: TR-AXXXX-XX GENERAL TOLERANCES (UNLESS SPECIFIED)	SCALE 1 : 1	DESIGN UNITS mm	<b>CHT 群匯科技股份有限公司</b> CHIUN HUEI Technology CO., LTD.  TITLE Micro SD Push Push Connector Top-Mount, H=1.5
X.XXX ± 0.10	DRAWN Allen	DATE 2020/02/26	
X.XX ± 0.25	CHECKED	DATE	
X.X ± 0.38	APPROVED	DATE	
ANGULAR ± 3°	DWG NO. PA0818-001	PART NO. SEE TABLE	
THIRD ANGLE PROJECTION	DWG REV. B	SHEET NO. 1 OF 1	