

REVISION HISTORY			
REV	DESCRIPTION	Drawing	DATE
01	PROPOSAL	Mei Chen	2018/09/04

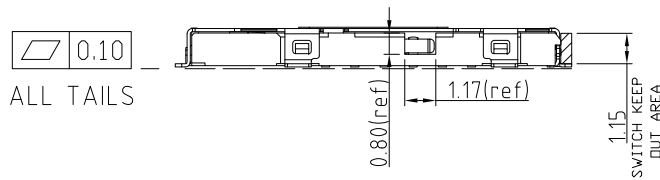
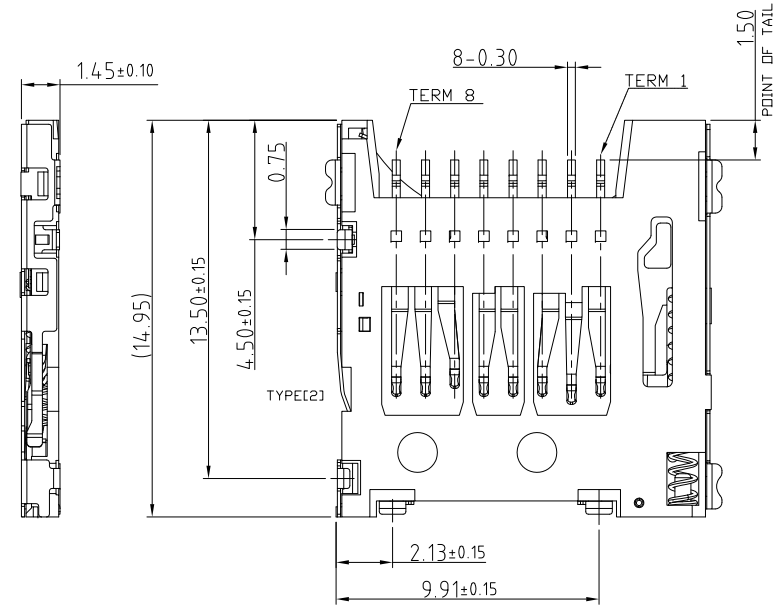
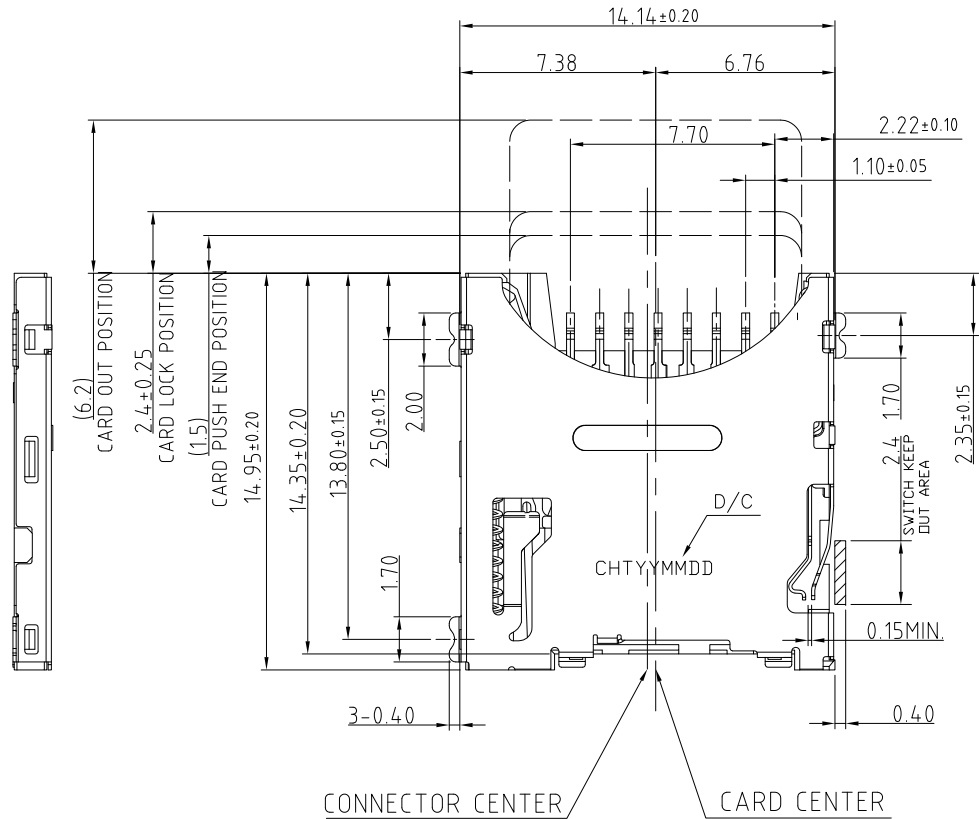

NOTES:

- MATERIAL:
 - 1.1 PLASTIC: THERMAL PLASTIC, UL 94V-0, COLOR: BLACK
 - 1.2 CONTACT: COPPER ALLOY
 - 1.3 SLIDER: THERMAL PLASTIC, UL 94V-0, COLOR: BLACK
 - 1.4 SPRING: STAINLESS STEEL
 - 1.3 SHELL: STAINLESS STEEL
- FINISH:
 - 2.1 TERMINAL: 50u" MIN. NICKEL PLATED OVERALL
 - 2.2 CONTACT: SELECTIVE GOLD PLATED, SEE TABLE A
 - 2.3 TAIL: 100u" MATT-TIN PLATED
 - 2.4 SHELL: 50u" MIN. NICKEL PLATED OVERALL
- PRODUCT SPECIFICATION REFER TO SP-A0640-01
- PACKAGE DRAWING REFER TO PA0640-01
- PRODUCT MUST CONFORM TO RoHS AND HALOGEN FREE REQUIREMENT

TERM 1	DATA 2
TERM 2	CD/DATA 3
TERM 3	CMD
TERM 4	VDD
TERM 5	CLK
TERM 6	VSS
TERM 7	DATA 0
TERM 8	DATA 1

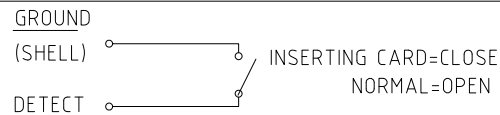

TABLE

FIH P/N	TABLE A GOLD PLATING THICKNESS
A0640-0003	Au30u
A0640-0001	G/F

PRODUCT SPECIFICATION: DOC.No: SP-AXXX-XX	SCALE 1 : 1	DESIGN UNITS mm
TEST REPORT DOC.No: TR-AXXX-XX	DRAWN Mei Chen	DATE 2018/09/04
GENERAL TOLERANCES (UNLESS SPECIFIED)	CHECKED	DATE
x.xxx ± 0.10	APPROVED	DATE
x.xx ± 0.25		
x.x ± 0.38		
ANGULAR ± 3°	DWG NO. SA0640-001	
THIRD ANGLE PROJECTION		



CHT 群匯科技股份有限公司
CHUIN HUEI Technology CO., LTD.

TITLE
TF Push 1.45H CONN

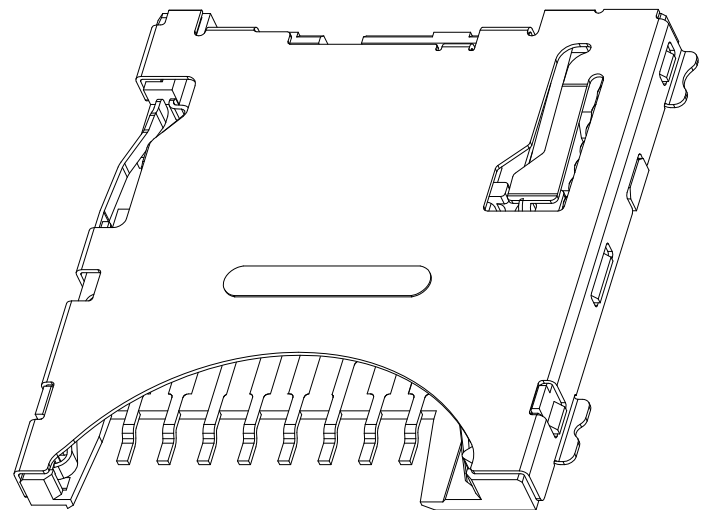
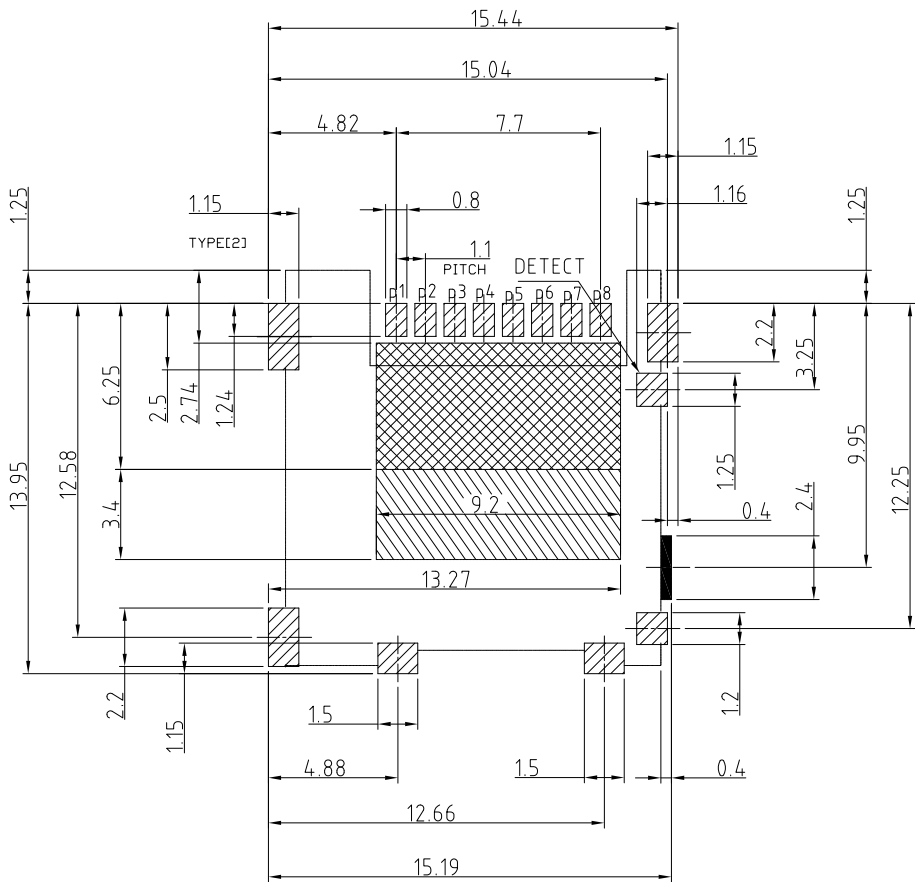
PART NO. TABLE A	DWG REV. 01	SHEET NO. 1 OF 2
---------------------	----------------	---------------------



RECOMMENDED
PCB PATTERN LAYOUT(TOP VIEW)
TOLERANCE: ±0.05

 SOLDERPROHIBITED AREA
  PROHIBITED AREA
  PATTERN PROHIBITED AREA

PRODUCT SPECIFICATION: DOC.No: SP-Axxxx-xx		SCALE 1 : 1	DESIGN UNITS mm	CHT 群匯科技股份有限公司 CHIUN HUEI Technology CO., LTD.
TEST REPORT DOC.No: TR-Axxxx-xx		DRAWN Mei Chen	DATE 2018/09/04	
GENERAL TOLERANCES (UNLESS SPECIFIED)		CHECKED	DATE	TITLE TF Push 1.45H CONN
x.xxx	± 0.10	APPROVED	DATE	
x.xx	± 0.25			
x.x	± 0.38			
ANGULAR ± 3°		DWG NO. SA0640-001	PART NO. TABLE A	DWG REV. 01
THIRD ANGLE PROJECTION				SHEET NO. 2 OF 2

REVISION HISTORY			
REV	DESCRIPTION	Drawing	DATE
01	PROPOSAL	Mei Chen	2018/09/10

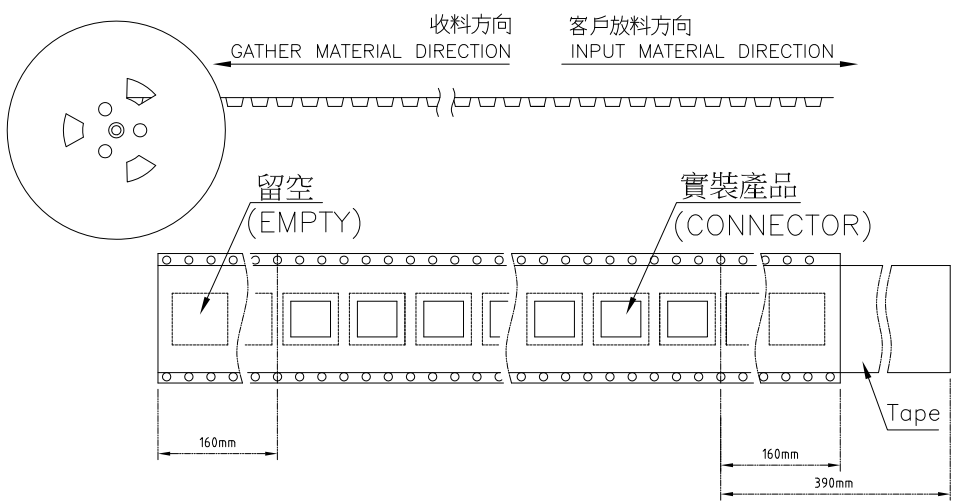
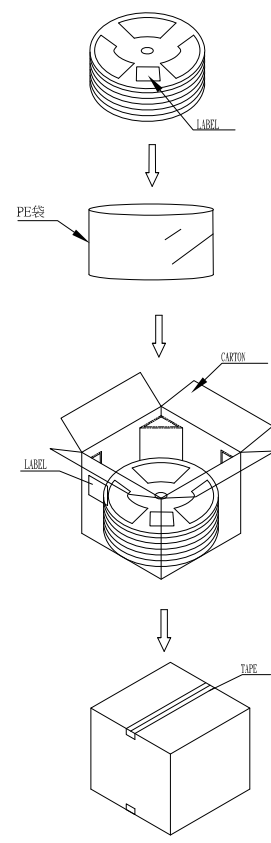
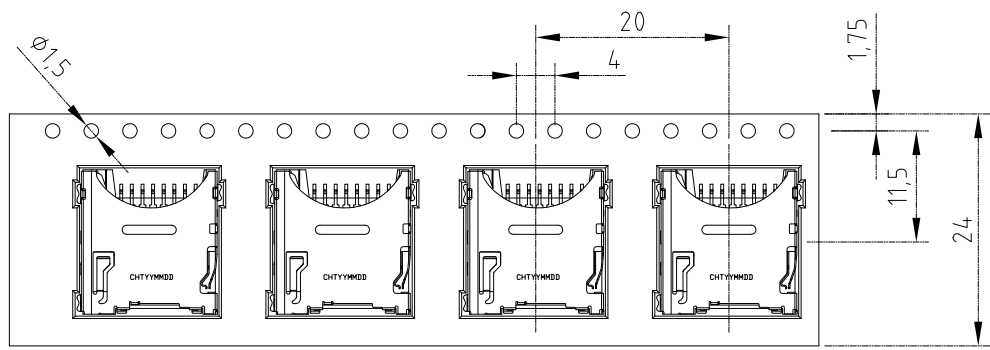

1. COVER TAPE PEELING FORCE:

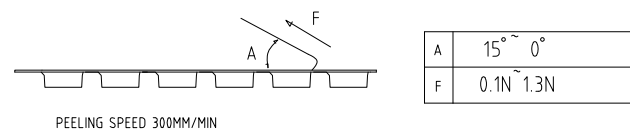

PEELING SPEED 300MM/MIN

2. PART DIMENSIONS MEET EIA-481-D REQUIREMENT

PRODUCT P/N	PARTS PER SHIPPING CARTON	PARTS PER REEL (S.P.Q.)	TOTAL REELS PER SHIPPING CARTON
A0640-0001	15000(PCS)	1500(PCS)	10
A0640-0001			
PRODUCT SPECIFICATION DOC.No: SP-Axxxx-xx TEST REPORT DOC.No: TR-Axxxx-xx GENERAL TOLERANCES (UNLESS SPECIFIED) X.XXX ± 0.10 X.XX ± 0.25 X.X ± 0.38 ANGULAR ± 3°		SCALE 1 : 1 DESIGN UNITS mm DRAWN Mei Chen DATE 2018/09/10 CHECKED DATE APPROVED DATE	
THIRD ANGLE PROJECTION		CHT 群匯科技股份有限公司 CHIUN HUEI Technology CO., LTD. TITLE TF Push 1.45H CONN	
DWG NO. PA0640-001	PART NO. A0640-0001	DWG REV. 01	SHEET NO. 1 OF 1