

REVISION HISTORY			
REV	DESCRIPTION	Drawing	DATE
01	PROPOSAL	Mei Chen	2014/11/05

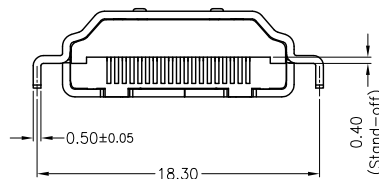

NOTES:
1. MATERIAL AND PLATING:
Housing: LCP+30%G.F,UL94V-0,Black
Contact: Brass, Au And Sn Plated.
Shell: SK7, Ni Plated.

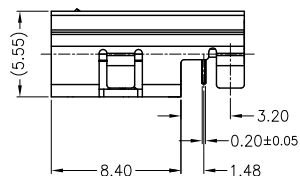
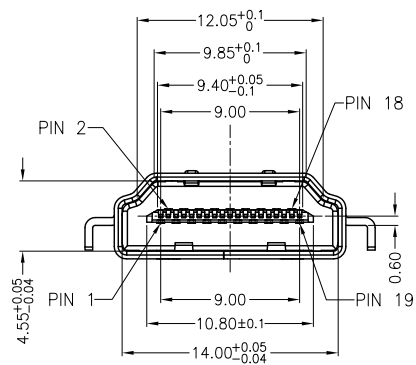
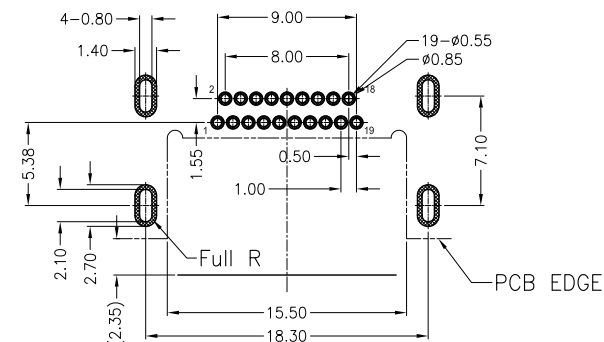
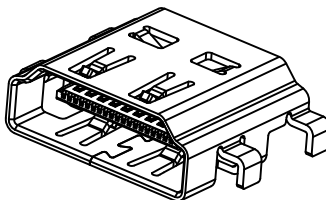
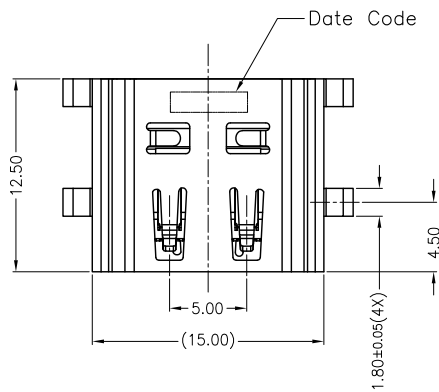
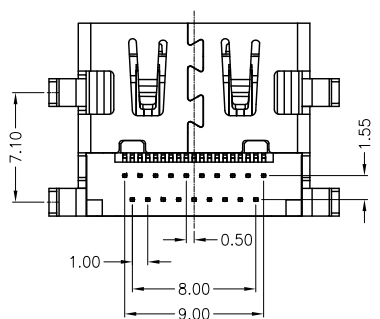

PRODUCT SPECIFICATION: DOC.No: SP-AXXXX-XX	SCALE 1 : 1	DESIGN UNITS mm	FULLINHOPE Technology, LTD.	
TEST REPORT DOC.No: TR-AXXXX-XX	DRAWN Mei Chen	DATE 2014/11/05	TITLE HDMI A Type Receptacle DIP Product,CH=0.6mm	
GENERAL TOLERANCES (UNLESS SPECIFIED)	CHECKED	DATE		
X.XXX ± 0.20	APPROVED	DATE		
X.XX ± 0.20				
X.X ± 0.25				
ANGULAR ± 3°				
THIRD ANGLE PROJECTION	DWG NO. SA0309-001	PART NO. A0309-0001	DWG REV. 01	SHEET NO. 1 OF 1

REVISION HISTORY			
REV	DESCRIPTION	Drawing	DATE
01	PROPOSAL	Mei Chen	2014/11/06

PACKAGING INSTRUCTION I:

1. STAPLES SHOULD ONLY BE USED TO SET UP CARTON
ALL CARTONS CLOSURES MUST BE DONE WITH TAPE.
2. FILL PACKAGING REEL WITH THE QUANTITIES AS INDICATED
IN THE CHART.

PRODUCT P/N	PARTS PER SHIPPING CARTON	PARTS PER REEL (S.P.Q.)	TOTAL REELS PER PRIMARY CARTON
A0309-0001	4000 (PCS)	500 (PCS)	8

1. QUANTITY: 500 PCS

2. COVER TAPE PEELING FORCE:

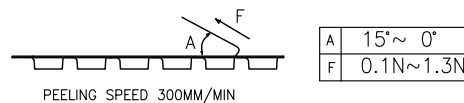

3. PART DIMENSIONS MEET EIA-481-D REQUIREMENT

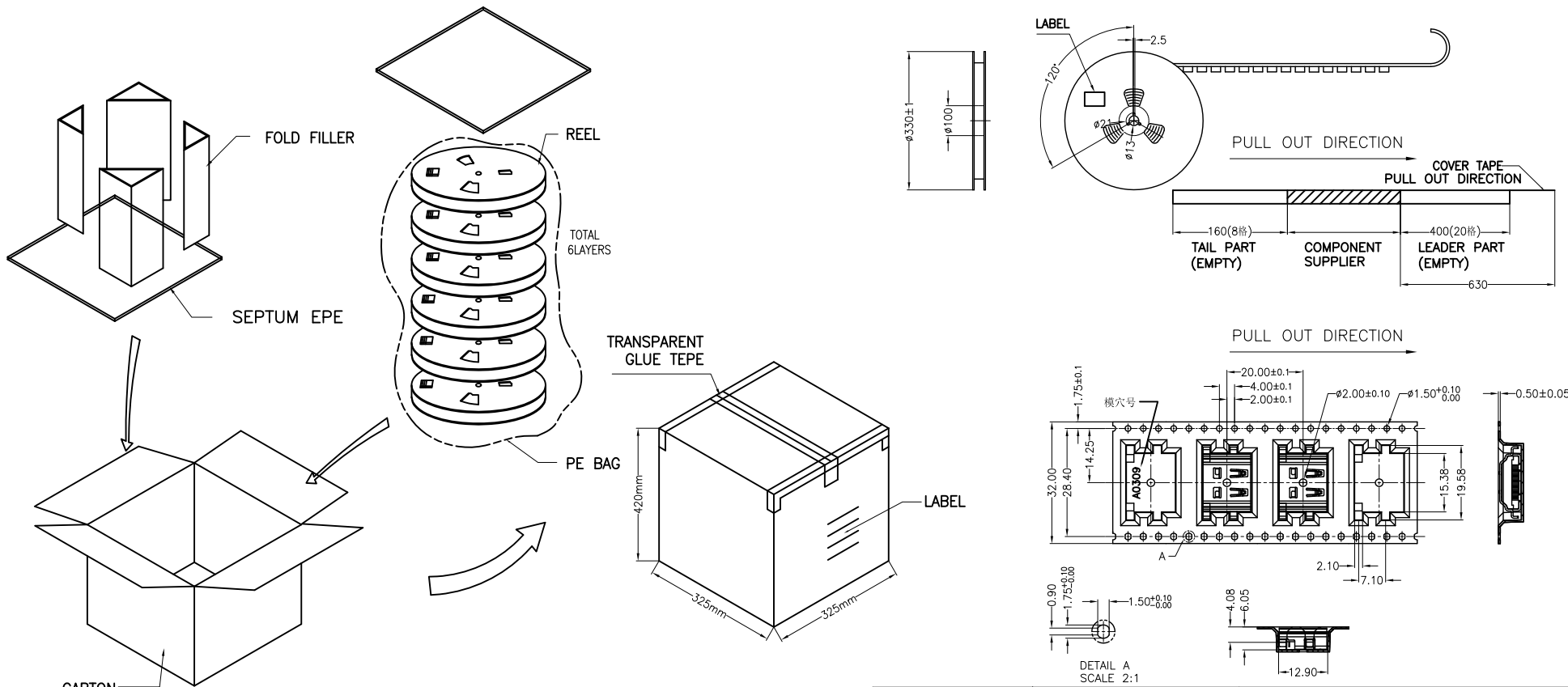

PRODUCT SPECIFICATION: DOC.No: SP-AXXX-XX	SCALE 1 : 1	DESIGN UNITS mm	FULLINHOPE Technology, LTD.	
TEST REPORT DOC.No: TR-AXXX-XX	DRAWN Mei Chen	DATE 2014/11/06	TITLE HDMI A Type Receptacle DIP Product, CH=0.6mm	
GENERAL TOLERANCES (UNLESS SPECIFIED)	CHECKED	DATE		
X.XXX ± 0.20	APPROVED	DATE		
X.XX ± 0.20			PART NO. A0309-0001	DWG. REV. 01
X.X ± 0.25				SHEET NO. 1 OF 1
ANGULAR ± 3°				
THIRD ANGLE PROJECTION	DWG NO. PA0309-001			