

HF

REVISION HISTORY

REV	DESCRIPTION	Drawing	DATE
01	PROPOSAL	Mei Chen	2016/06/02
02	PROPOSAL	Mei Chen	2016/06/08
03	PROPOSAL	Mei Chen	2016/06/21
04	ADD MYLAR MATERIAL	Mei Chen	2016/06/21

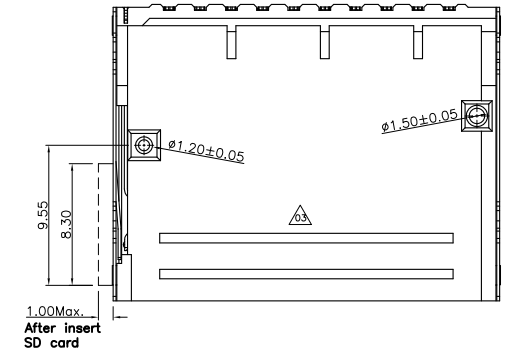
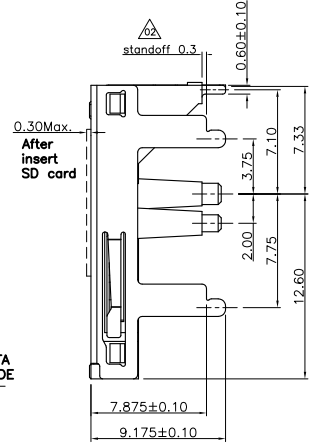
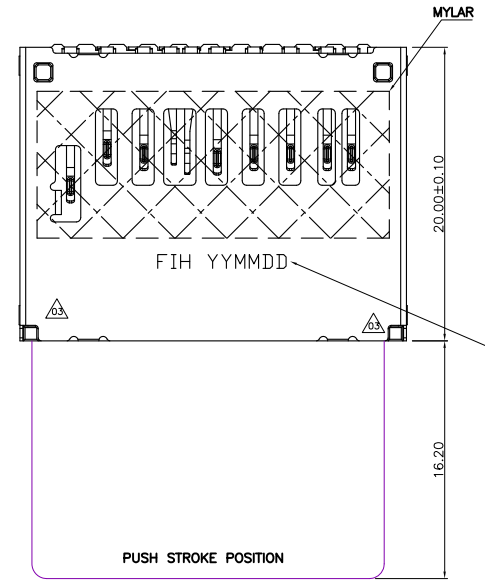
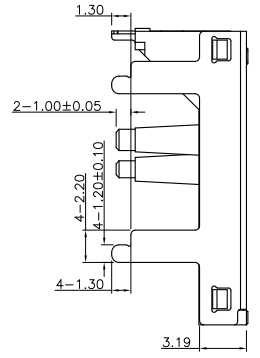
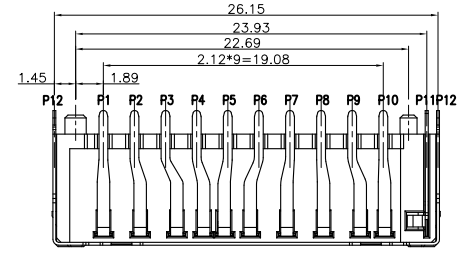

- NOTES: 1. MATERIAL:
 HOUSING: LCP E130i , 94 V-0, COLOR: BLACK.
 CONTACT: C5210 .
 SHELL: SUS 304.
 Myler: PI FILM, HIGH TEMP,T=0.1mm
 2. PLATING:
 CONTACT: GOLD PLATING
 ALL OVER 50u" MIN NICKEL AND 120u"MIN Tin
 ALL OVER 50u" MIN NICKEL ON SOLDER AREA
 SHELL: 50 u" MIN. NICKEL UNDERPLATING OVER ALL
 3. RoHS + HF COMPLIANT PRODUCTS.
 4. DATE CODE: YY(YEAR),MM(MONTH),DD(DDATE)

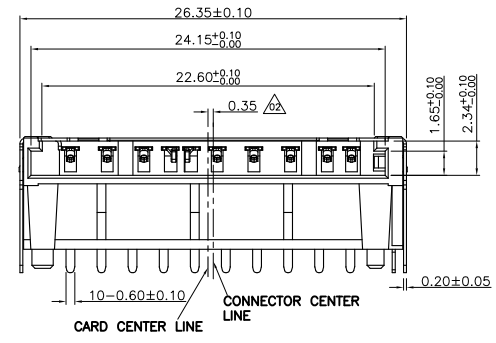

WITHOUT CARD		CARD INSERTED:LOCK		CARD INSERTED:UNLOCK	
W/P #11	GND #12	W/P #11	GND #12	W/P #11	GND #12
C/D #04	VSS1 #05	C/D #04	VSS1 #05	C/D #04	VSS1 #05

PRODUCT SPECIFICATION: DC.No: SP-Axxxx-xx	SCALE 1 : 1	DESIGN UNITS mm	FULLINHOPE Technology, LTD. SD CARD CONNECTOR TYPE FOR REVERSE,H=7.875
TEST REPORT DC.No: TR-Axxxx-xx	DRAWN Mei Chen	DATE 2016/06/02	
GENERAL TOLERANCES (UNLESS SPECIFIED)	CHECKED	DATE	
X.XXX ± 0.25 X.XX ± 0.25 X.X ± 0.38	APPROVED	DATE	
ANGULAR ± 3°	DWG NO. SA0442-001	PART NO. A0442-0001	DWG REV. 04
THIRD ANGLE PROJECTION			SHEET NO. 1 OF 2

HF

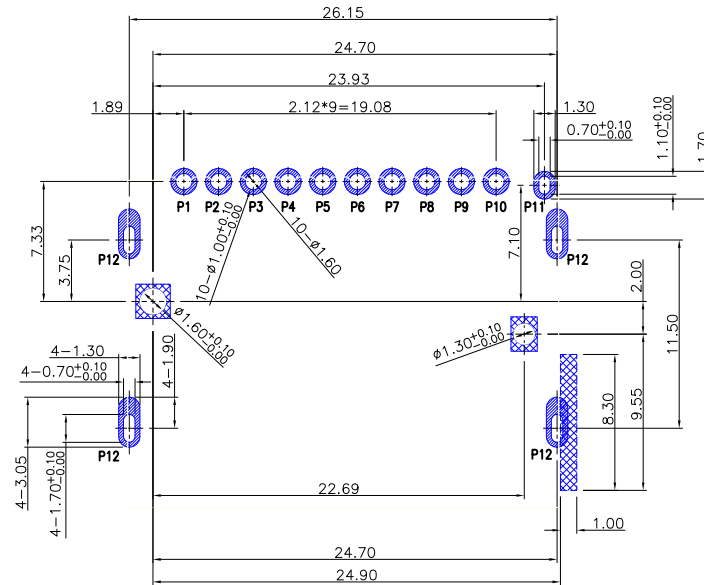

RECOMMEND P.C.B LAYOUT
 GENERAL TOLERANCE ± 0.05

 layout space of the products:
 No trace, no test point,
 no via hole, no ground area.

Pin Define

Connector Pin No.	SD Card Pin No.	Pin Define
P1	P9	DAT2
P2	P1	DAT3
P3	P2	CMD
P4		CD
P5	P3	VSS1
P6	P4	VDD
P7	P5	CLK
P8	P6	VSS2
P9	P7	DAT0
P10	P8	DAT1
P11		W/P
P12		GND
		GND
		GND
		GND

PRODUCT SPECIFICATION: DOC.No: SP-Axxxx-xx	SCALE 1 : 1	DESIGN UNITS mm	FULLINHOPE Technology, LTD.	
TEST REPORT DOC.No: TR-Axxxx-xx	DRAWN Mei Chen	DATE 2016/06/02	TITLE SD CARD CONNECTOR TYPE FOR REVERSE,H=7.875	
GENERAL TOLERANCES (UNLESS SPECIFIED)	CHECKED	DATE		
X.XXX ± 0.25	APPROVED	DATE		
X.XX ± 0.25				
X.X ± 0.38				
ANGULAR $\pm 3^\circ$	DWG NO. SA0442-001	PART NO. A0442-0001	DWG REV. 04	SHEET NO. 2 OF 2
 THIRD ANGLE PROJECTION				

10

9

8

7

6

5

4

3

2

1

REVISION HISTORY

REV	DESCRIPTION	Drawing	DATE
01	PROPOSAL	Mei Chen	2016/06/02
02	PROPOSAL	Mei Chen	2016/06/21

GATHER MATERIAL DIRECTION

INPUT MATERIAL DIRECTION

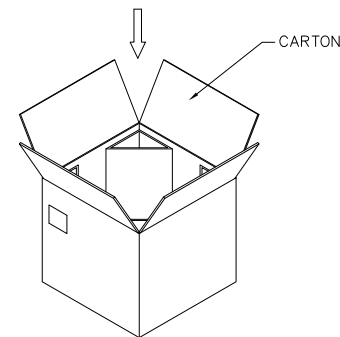
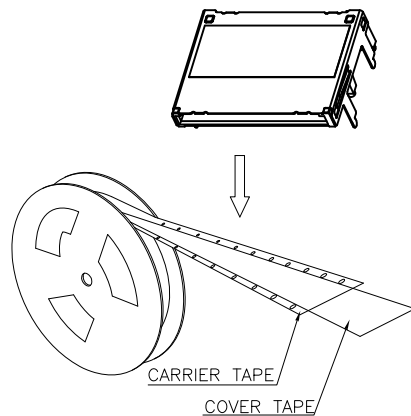
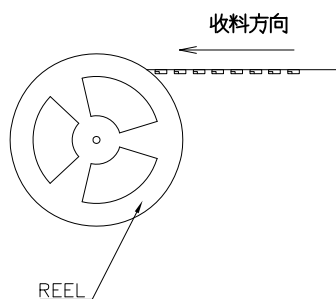
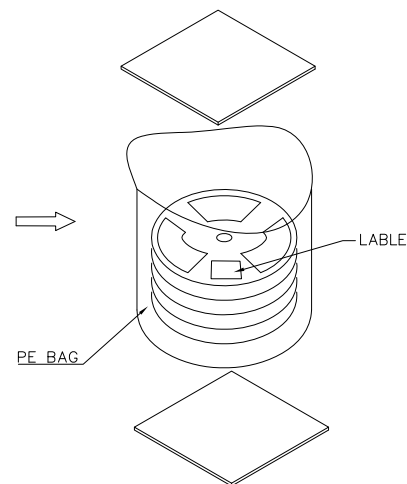
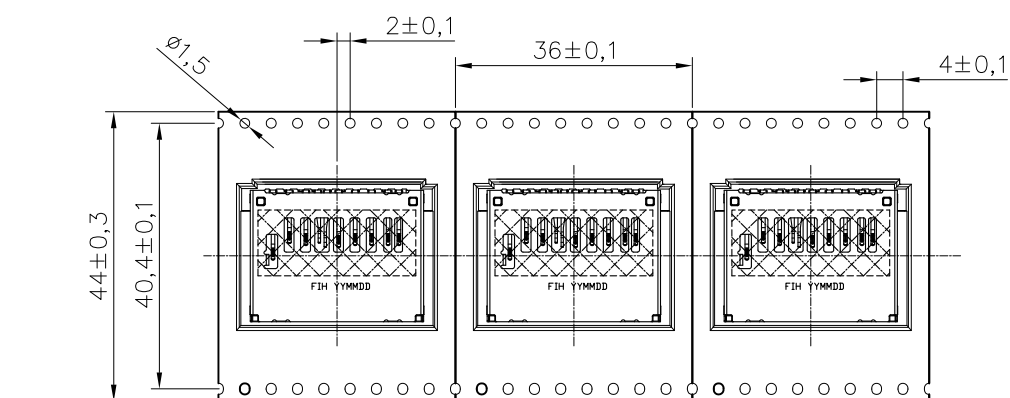

1. COVER TAPE PEELING FORCE:

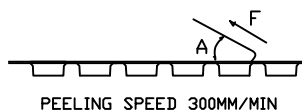

A	15°~ 0°
F	0.1N~1.3N

2. PART DIMENSIONS MEET EIA-481-2-A REQUIREMENT

PRODUCT P/N	PARTS PER SHIPPING CARTON	PARTS PER REEL (S.P.Q.)	TOTAL REELS PER SHIPPING CARTON
A0442-0001	750(PCS)	150(PCS)	5

PRODUCT SPECIFICATION: DSC.No: SP-Axxxx-xx	SCALE 1 : 1	DESIGN UNITS mm	FULLINHOPE Technology, LTD.	
TEST REPORT DCC.No: TR-Axxxx-xx	DRAWN Mei Chen	DATE 2016/06/02	TITLE SD CARD CONNECTOR TYPE FOR REVERSE,H=7.875	
GENERAL TOLERANCES (UNLESS SPECIFIED)	CHECKED	DATE		
X.XXX ± 0.20				
X.XX ± 0.20				
X.X ± 0.25	APPROVED	DATE		
ANGULAR ± 3°				
THIRD ANGLE PROJECTION	DWG NO. PA0442-001	PART NO. A0442-0001	DWG REV. 02	SHEET NO. 1 OF 1

9

8

7

6

5

4

3

2

1