

REVISION HISTORY		
REV	DESCRIPTION	DATE
05	PCB Layout 增加說明	2020/04/15

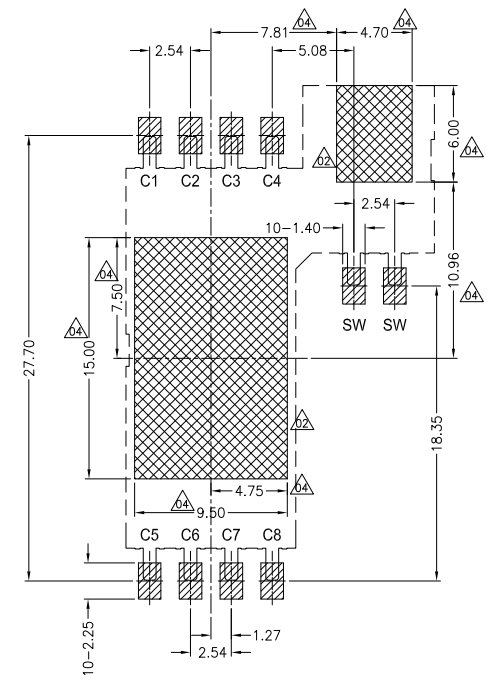

- [Hatched Box] PAD AREA
 - [Cross-hatched Box] PROHIBITED AREA
 - [Dashed Box] OTHER COMPONENT KEEPOUT AREA
- (限制區域, 此區域不可走線及放置PAD)

- NOTES:
- MATERIAL AND PLATING:
Housing: LCP+30%G.F, UL94V-0, Black
Contact: C5191, PLATED SEE TABLE
 - MECHANICAL CHARACTERISTIC
Contact Force: 0.2Nf-0.6Nf.
Durability: 100,000 Cycles.
 - ELECTRICAL CHARACTERISTIC
Current Rating: 10uA Min, 1.0A Max.
Voltage Rating: 30V AC.
Contact Resistance: 100m Ohm Max.
Insulation Resistance: 1000M Ohm Min
Dielectric Withstanding Voltage: 500V AC Min
 - TEMPERATURE
Operating Temperature: -40°C~+85°C
Storage Temperature: -60°C~+105°C

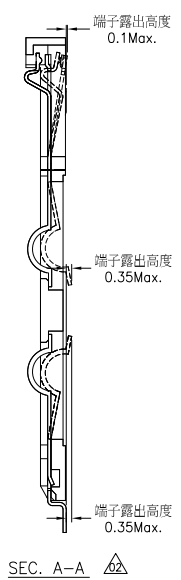
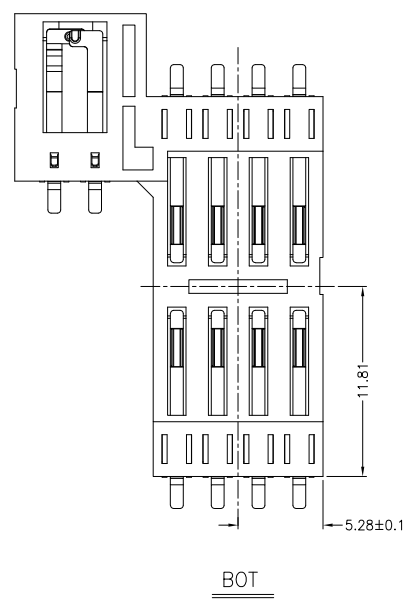
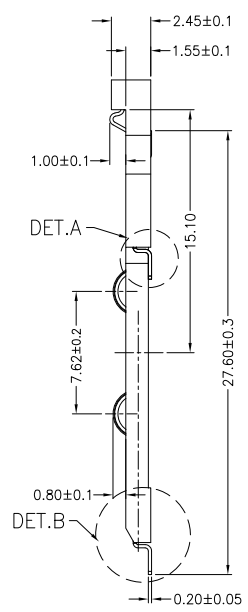
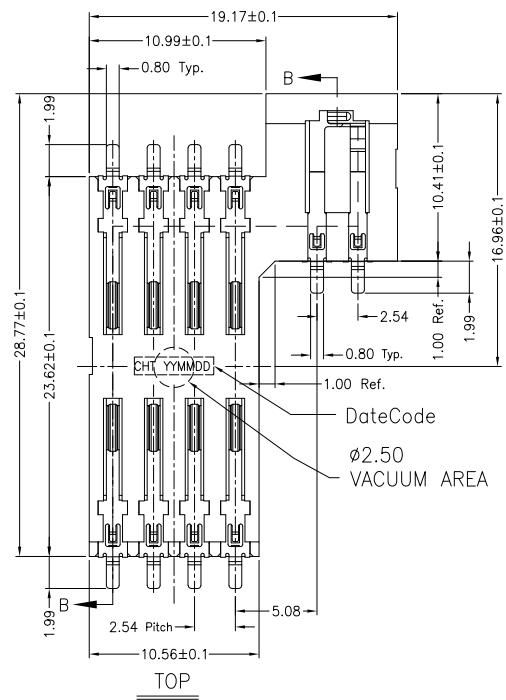
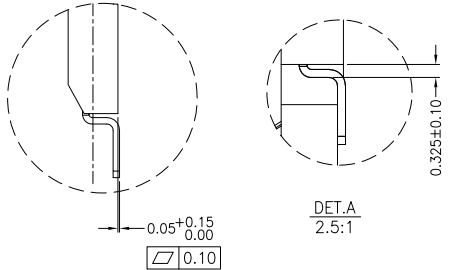
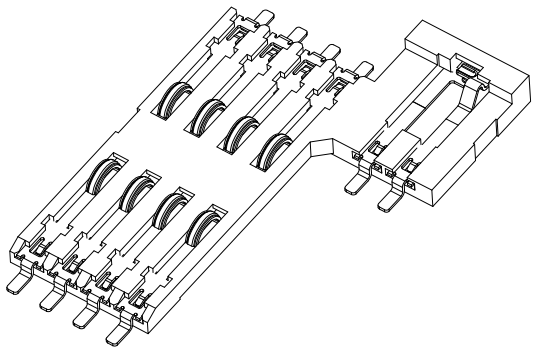

TABLE

FIH P/N	TABLE A GOLD PLATING THICKNESS
A0806-0003	Au 30u"
A0806-0001	G/F

PIN NO.	C1	C2	C3	C4	C5	C6	C7	C8	C9	C10
NAME	VCC	RST	CLK	C4	GND	VPP	I/O	VCC	SW-CD-GND	SW-CD

PRODUCT SPECIFICATION: DOC.No: SP-AXXXX-XX	SCALE 1 : 1	DESIGN UNITS mm
TEST REPORT DOC.No: TR-AXXXX-XX	DRAWN Allen	DATE 2020/03/16
GENERAL TOLERANCES (UNLESS SPECIFIED)	CHECKED	DATE
	APPROVED	DATE
	DWG NO. SA0806-001	PART NO. SEE TABLE
	THIRD ANGLE PROJECTION	DWG REV. 05
		SHEET NO. 1 OF 1

CHT 群匯科技股份有限公司
CHUIN HUEI Technology CO., LTD.

TITLE
SMART CARD SOCKET
PRODUCT

REVISION HISTORY			
REV	DESCRIPTION	Drawing	DATE
01	PROPOSAL	Allen	2020/03/25

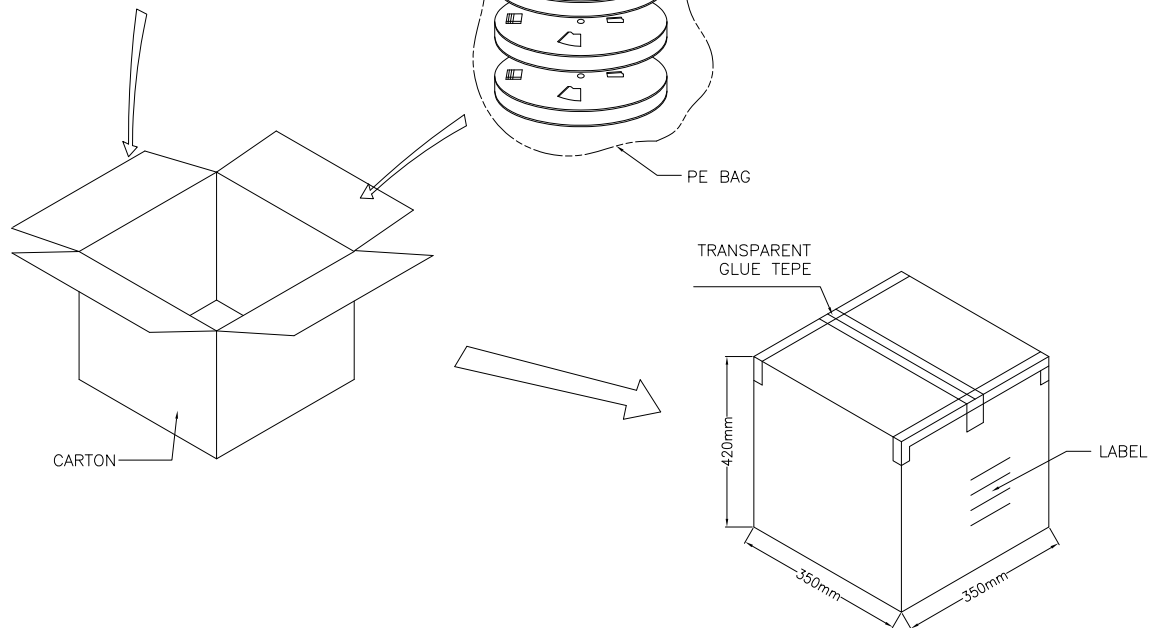
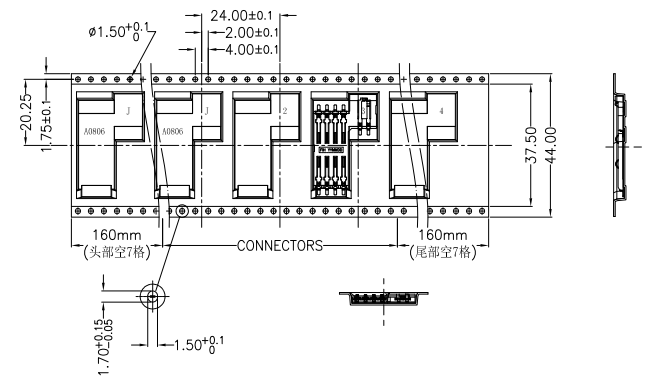
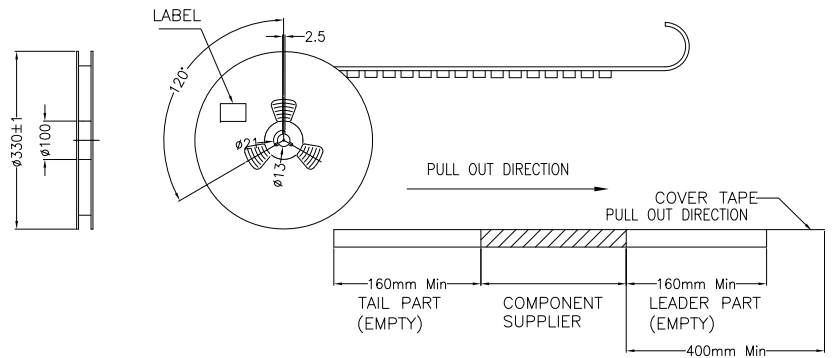
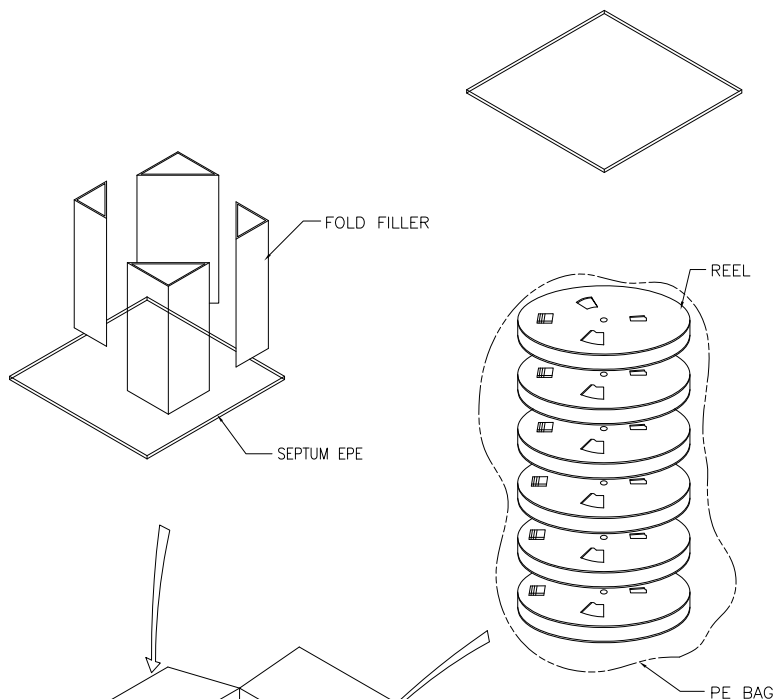

1. COVER TAPE PEELING FORCE:

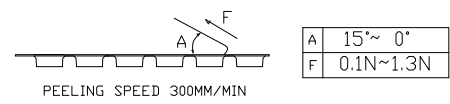

2. PART DIMENSIONS MEET EIA-481-2-A REQUIREMENT

PRODUCT P/N	PARTS PER SHIPPING CARTON	PARTS PER REEL	LOADED REEL PER SHIPPING CARTON
A0806-0003	6400	800	8
A0806-0001			

PRODUCT SPECIFICATION: DDC.No: SP-AXXXX-XX TEST REPORT DDC.No: TR-AXXXX-XX GENERAL TOLERANCES (UNLESS SPECIFIED)	SCALE	DESIGN UNITS	CHT 群匯科技股份有限公司 CHIUN HUEI Technology CO., LTD.
	1 : 1	mm	
DRAWN	DATE	TITLE	
Allen	2020/03/25		
X.XXX ± 0.10 X.XX ± 0.25 X.X ± 0.38 ANGULAR ± 3°	CHECKED	DATE	DWG NO. PA0806-001 PART NO. SEE TABLE DWG REV. 01 SHEET NO. 1 OF 1
THIRD ANGLE PROJECTION	APPROVED	DATE	