

REVISION HISTORY			
REV	DESCRIPTION	Drawing	DATE
01	PROPOSAL	Mei Chen	2019/10/08

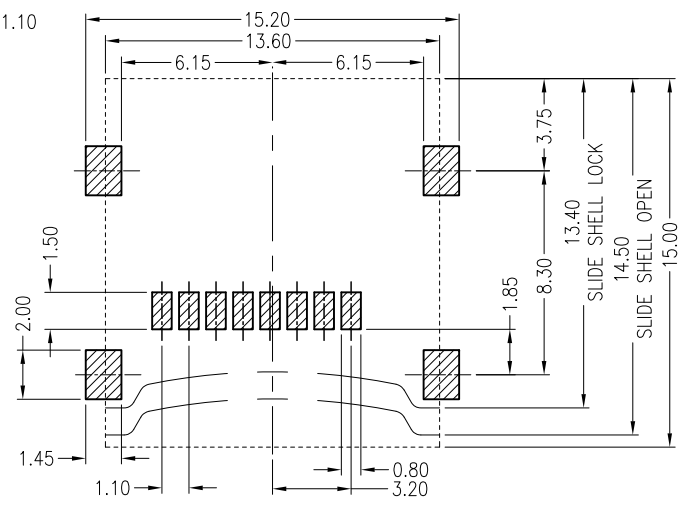
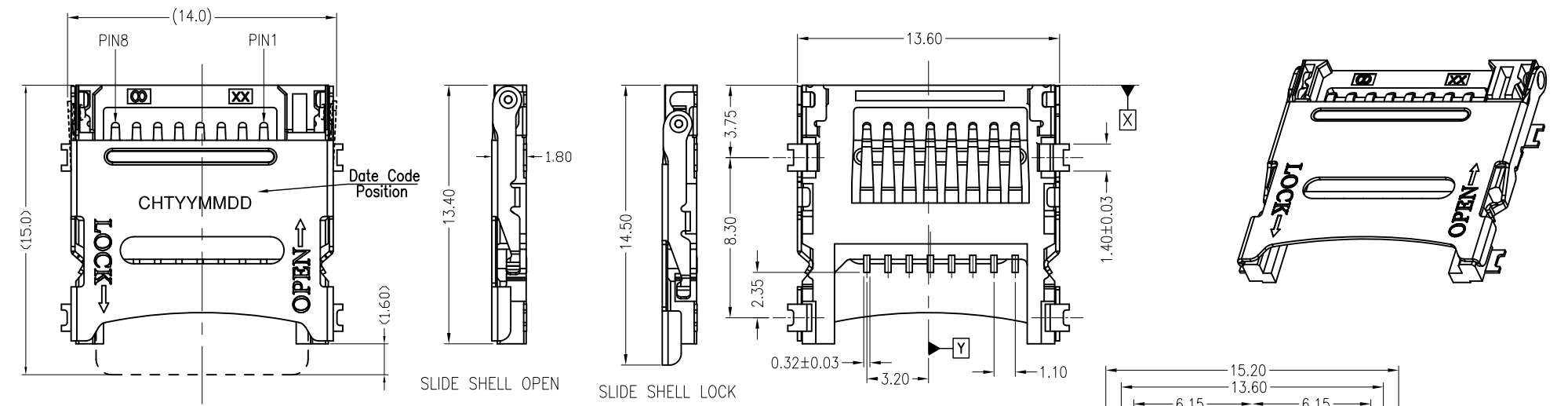

RECOMMENDED PCB LAYOUT

产品外形 焊盘

- NOTE:
- MATERIAL:
    - INSULATOR: HIGH TEMPERATURE THERMOPLASTIC, UL94V-0, COLOR:BLACK
    - CONTACT: COPPER ALLOY.
    - SHELL : STAINLESS STEEL
  - FINISH:
    - TERMINAL: 50 $\mu$ m MIN. NICKEL PLATED OVERALL
    - CONTACT: SELECTIVE GOLD PLATED, SEE TABLE A
    - TAIL: 100 $\mu$ m MIN MATT-TIN PLATED
    - SHELL : 50 $\mu$ m MIN. NICKEL PLATED OVERALL
  - PRODUCT SPECIFICATION REFER TO SP-A0770-01
  - PACKAGE DRAWING REFER TO PA0770-01
  - PRODUCT MUST CONFORM TO RoHS AND HALOGEN FREE REQUIREMENT

Pin No.	MICRO SD
PIN1	DAT2
PIN2	CD/DAT3
PIN3	CMD
PIN4	VDD
PIN5	CLK
PIN6	VSS
PIN7	DAT0
PIN8	DAT1

TABLE

FIH P/N	TABLE A GOLD PLATING THICKNESS
A0770-0003	Au30u
A0770-0001	G/F

PRODUCT SPECIFICATION: DOC.No: SP-A0770-01	SCALE 1 : 1	DESIGN UNITS mm
TEST REPORT DOC.No: TR-A0770-01	DRAWN Mei Chen	DATE 2019/10/08
GENERAL TOLERANCES (UNLESS SPECIFIED)	CHECKED	DATE
X.XXX ± 0.10	APPROVED	DATE
X.XX ± 0.25	DWG NO. SA0770-001	
X.X ± 0.38		
ANGULAR ± 3°		
THIRD ANGLE PROJECTION		

**CHT** 群匯科技股份有限公司  
CHUIN HUEI Technology CO., LTD.

TITLE  
MICRD SD CARD CONNECTOR  
HINGE TYPE H=1.8

PART NO. SEE TABLE	DWG REV. 01	SHEET NO. 1 OF 1
-----------------------	----------------	---------------------

REVISION HISTORY			
REV	DESCRIPTION	Drawing	DATE
01	PROPOSAL	Mei Chen	2019/10/08

GATHER MATERIAL DIRECTION ← INPUT MATERIAL DIRECTION →

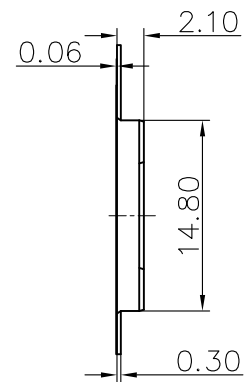
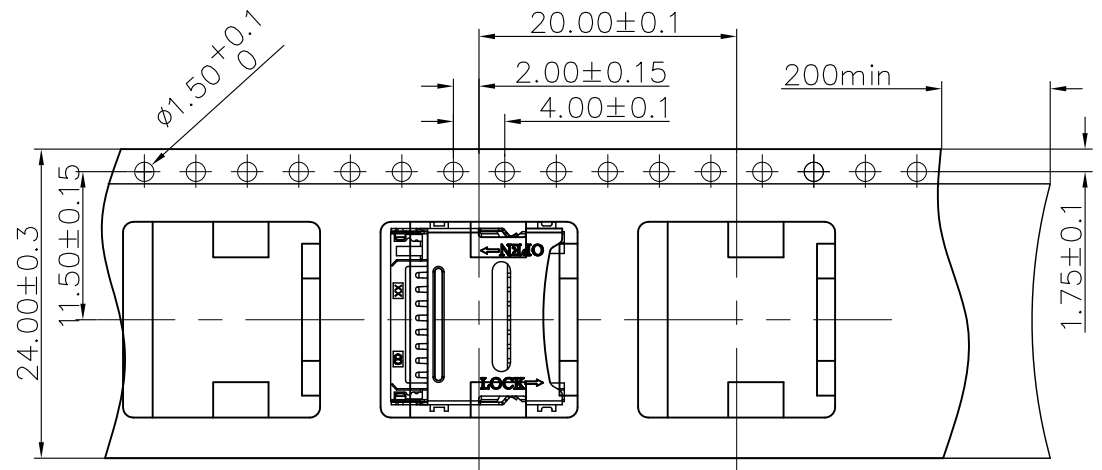

1. COVER TAPE PEELING FORCE:

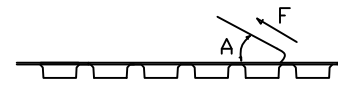

A	$15^\circ \sim 0^\circ$
F	$0.1\text{N} \sim 1.3\text{N}$

PEELING SPEED 200MM/MIN

2. PART DIMENSIONS MEET EIA-481-2-A REQUIREMENT

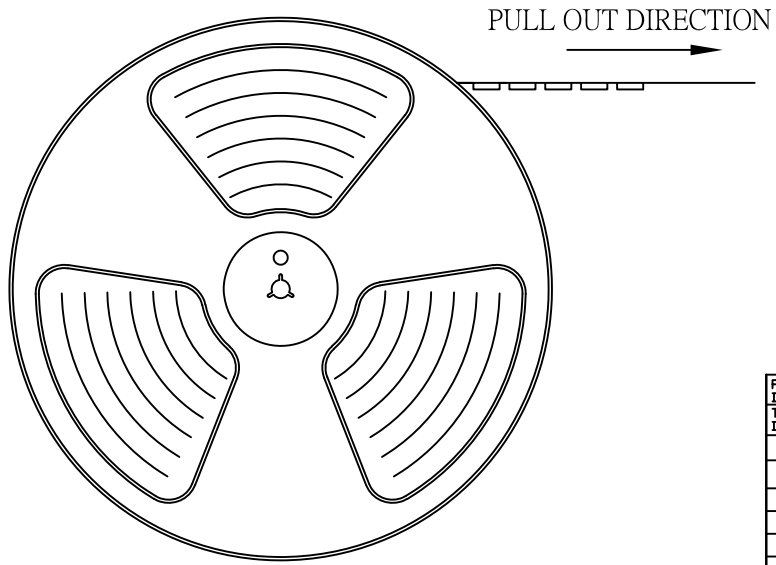
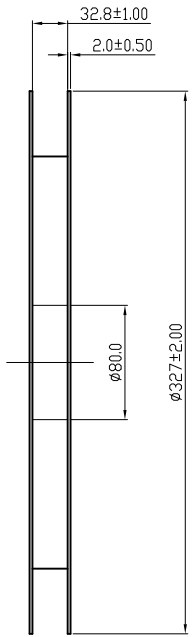
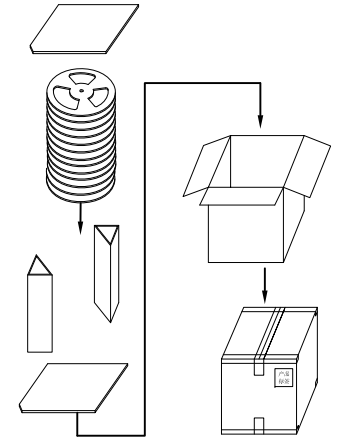

TABLE

PRODUCT P/N	PARTS PER SHIPPING CARTON	PARTS PER REEL (S.P.Q.)	TOTAL REELS PER SHIPPING CARTON
A0770-0003	10000(PCS)	1000(PCS)	10
A0770-0001			

PRODUCT SPECIFICATION: DOC.No: SP-XXXX-XX	SCALE 1 : 1	DESIGN UNITS mm
TEST REPORT DOC.No: TR-XXXX-XX	DRAWN Mei Chen	DATE 2019/10/08
GENERAL TOLERANCES (UNLESS SPECIFIED)	CHECKED	DATE
X.XXX ± 0.10	APPROVED	DATE
X.XX ± 0.25		
X.X ± 0.38		
ANGULAR ± 3°		
THIRD ANGLE PROJECTION	DWG NO. PA0770-001	PART NO. SEE TABLE

**CHT** 群匯科技股份有限公司  
CHIUN HUEI Technology CO., LTD.

TITLE  
MICRO SD CARD CONNECTOR  
HINGE TYPE H=1.8

DWG REV. 01	SHEET NO. 1 OF 1
----------------	---------------------