

REVISION HISTORY			
REV	DESCRIPTION	Drawing	DATE
08	修改形状	Allen	2020/09/09

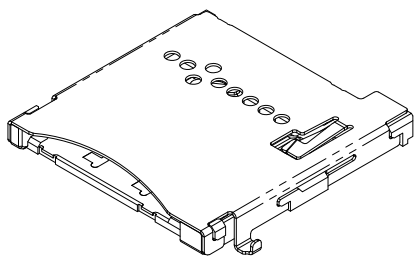
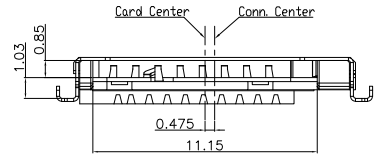
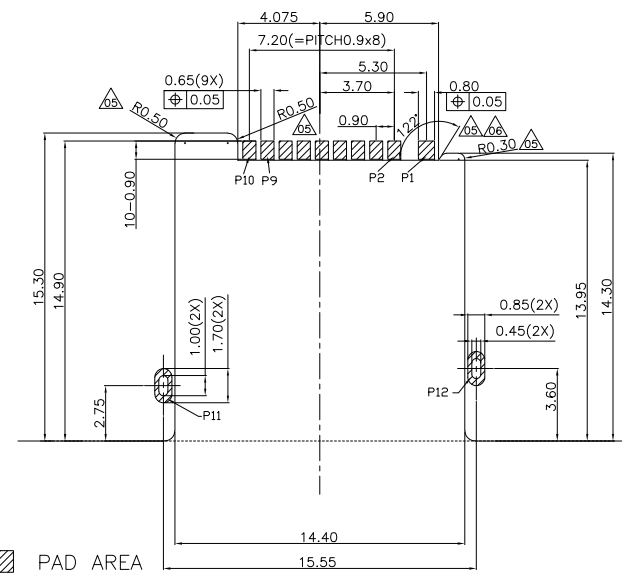
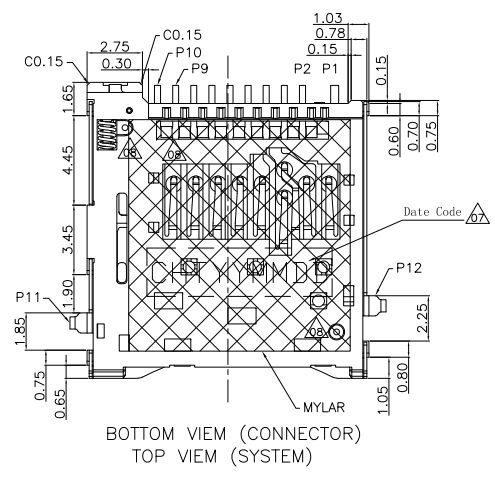
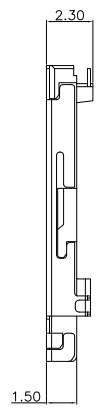
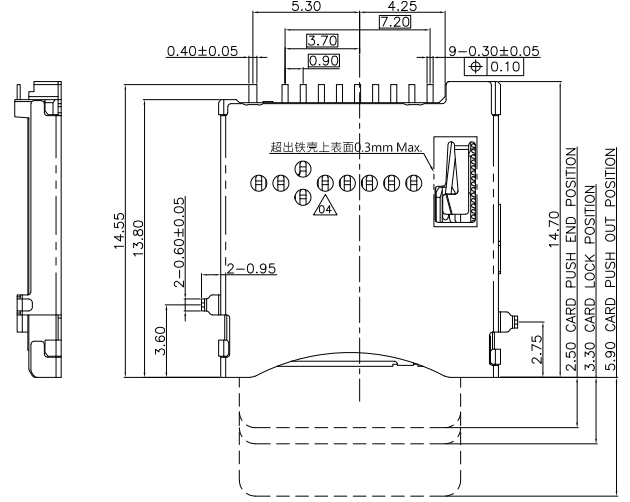
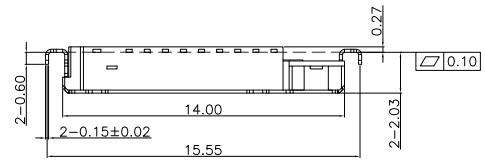

Opening/Close of Switch

	Card Detect Switch	
Card Uninsertion	Open	
Card Half Insertion	Open	
Card Insertion	Close	
N/O	Open	Close

Recommended P.C.B LAYOUT
 BOTTOM VIEW(CONNECTOR) (TOLERANCE+/-0.05)
 TOP VIEW(SYSTEM)

- NOTE:
- MATERIAL:
 - INSULATOR: HIGH TEMPERATURE THERMOPLASTIC, UL94V-0, COLOR:BLACK
 - CONTACT: COPPER ALLOY.
 - SHELL: STAINLESS STEEL.
 - FINISH:
 - CONTACT: SELECTIVE GOLD PLATED, SEE TABLE A
 - SOLDERTAIL AREA: MATTE TIN 80u" OVER NI
 - SHELL: SOLDERABILITY Ni PLATING OVER ALL
 - PRODUCT SPECIFICATION REFER TO SP-A0787-01
 - PACKAGE DRAWING REFER TO PA0787-01
 - PRODUCT MUST CONFORM TO RoHS AND HALOGEN FREE REQUIREMENT

Pin No.	Pin Assignment
P1	MICRO SD CD
P2	MICRO SD DAT1
P3	MICRO SD DAT0
P4	MICRO SD VSS
P5	MICRO SD CLK
P6	MICRO SD VDD
P7	MICRO SD CMD
P8	MICRO SD CD/DAT3
P9	MICRO SD DAT2
P10	MICRO SD GND
P11	MICRO SD GND
P12	MICRO SD GND

TABLE

FIH P/N	TABLE A GOLD PLATING THICKNESS
A0787-0003	Au 30u"
A0787-0001	G/F

PRODUCT SPECIFICATION: DOC.No: SP-XXXX-XX	SCALE 1 : 1	DESIGN UNITS mm
TEST REPORT DOC.No: TR-XXXX-XX	DRAWN Allen	DATE 2020/01/13
GENERAL TOLERANCES (UNLESS SPECIFIED)	CHECKED	DATE
X.XXX ± 0.10	APPROVED	DATE
X.XX ± 0.25		
X.X ± 0.38		
ANGULAR ± 3°		
THIRD ANGLE PROJECTION	DWG NO. SA0787-001	

CHT 群匯科技股份有限公司
 CHIUN HUEI Technology CO., LTD.

TITLE
 Micro SD PUSH PUSH
 RVS. SINK H=2.3

PART NO. SEE TABLE	DWG REV. 08	SHEET NO. 1 OF 1
-----------------------	----------------	---------------------

REVISION HISTORY			
REV	DESCRIPTION	Drawing	DATE
02	修改擺放方向	Allen	2020/04/20

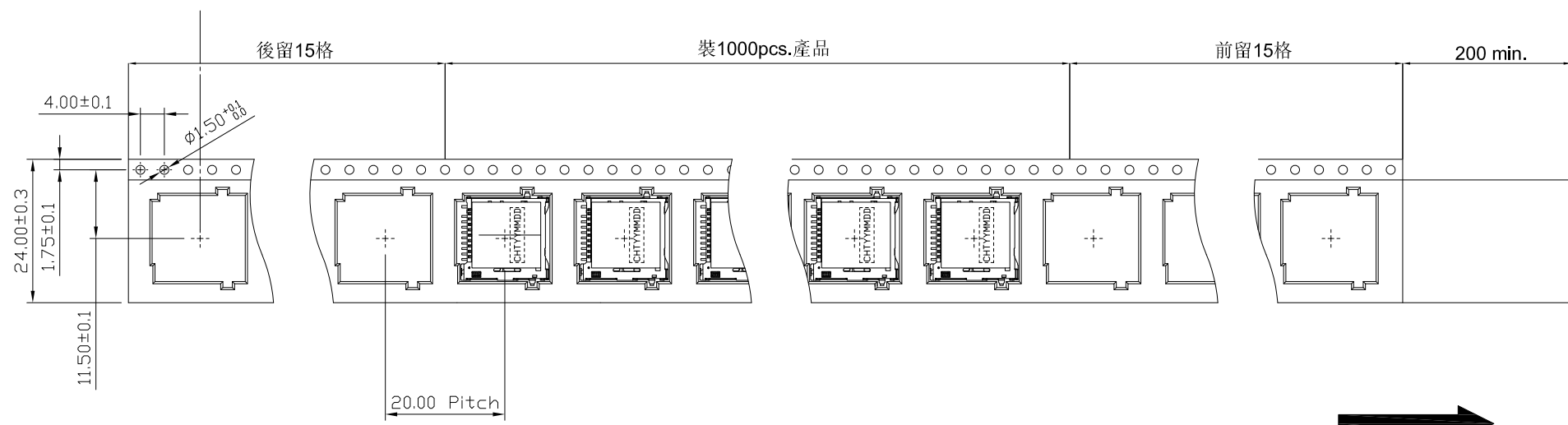

出料方向
PULL OUT DIRECTEON

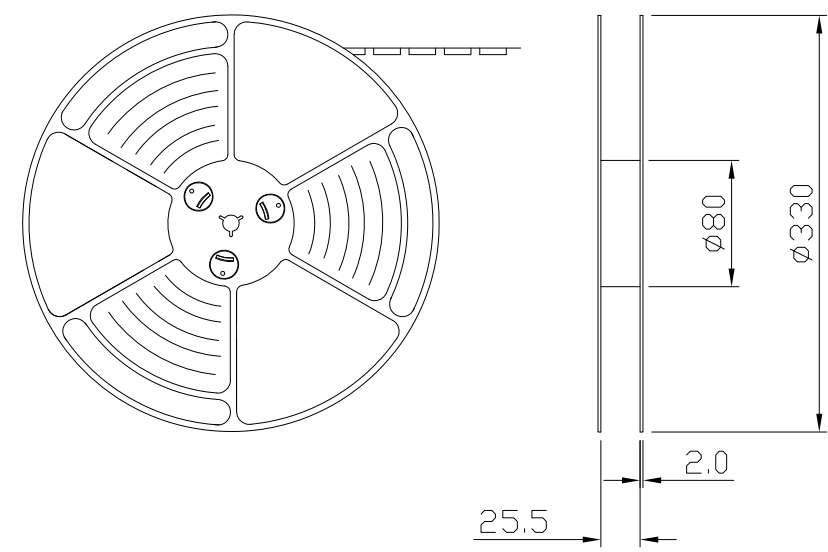

出料方向
PULL OUT DIRECTEON

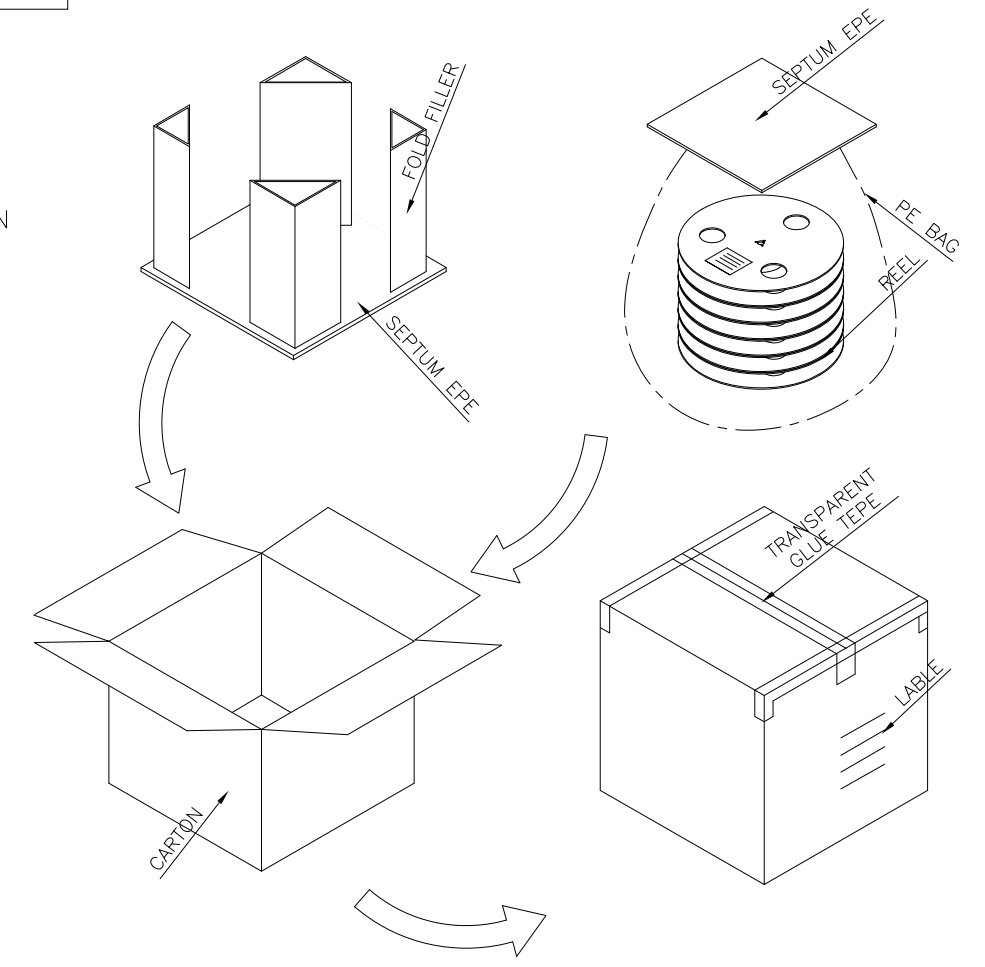

1. COVER TAPE PEELING FORCE:

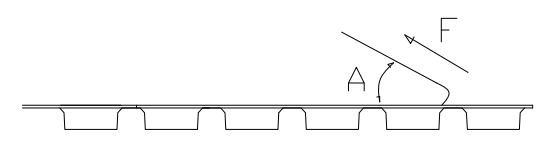

A	15°~ 0°
F	0.1N~1.3N

PEELING SPEED 300MM/MIN

2. PART DIMENSIONS MEET EIA-481-2-A REQUIREMENT

PRODUCT P/N	PARTS PER SHIPPING CARTON	PARTS PER REEL (S.P.Q.)	TOTAL REELS PER SHIPPING CARTON	
A0787-0003	8000(PCS)	1000(PCS)	8	
A0787-0001				
PRODUCT SPECIFICATION: DOC.No: SP-AXXXX-XX	SCALE 1 : 1	DESIGN UNITS mm	CHT 群匯科技股份有限公司 CHIUN HUEI Technology CO., LTD.	
TEST REPORT DOC.No: TR-AXXXX-XX	DRAWN Allen	DATE 2020/03/18		
GENERAL TOLERANCES (UNLESS SPECIFIED)	CHECKED	DATE		
X.XXX ± 0.10	APPROVED	DATE		
X.XX ± 0.25				
XX ± 0.38				
ANGULAR ± 3°			TITLE Micro SD PUSH PUSH RVS. SINK H=2.3	
THIRD ANGLE PROJECTION	DWG NO. PA0787-001	PART NO. see tabel	DWG REV. 02	SHEET NO. 1 OF 1