

REVISION HISTORY			
REV	DESCRIPTION	Drawing	DATE
C	增加尺寸標註	Mei Chen	2019/10/21

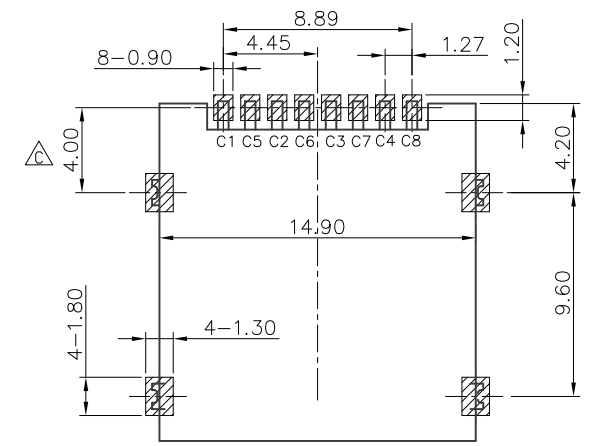

RECOMMENDED PCB LAYOUT
 TOLERANCE: ±0.05
 THERE SHOULD NOT BE ANY CIRCUITRIES
 IN THE LAYOUT SPACE OF THE PRODUCT.

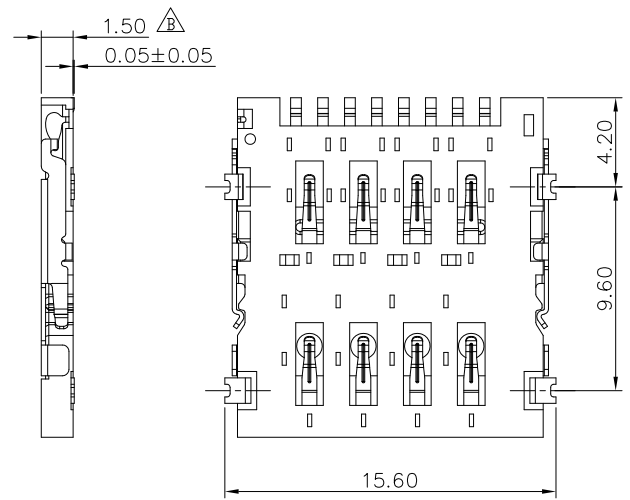
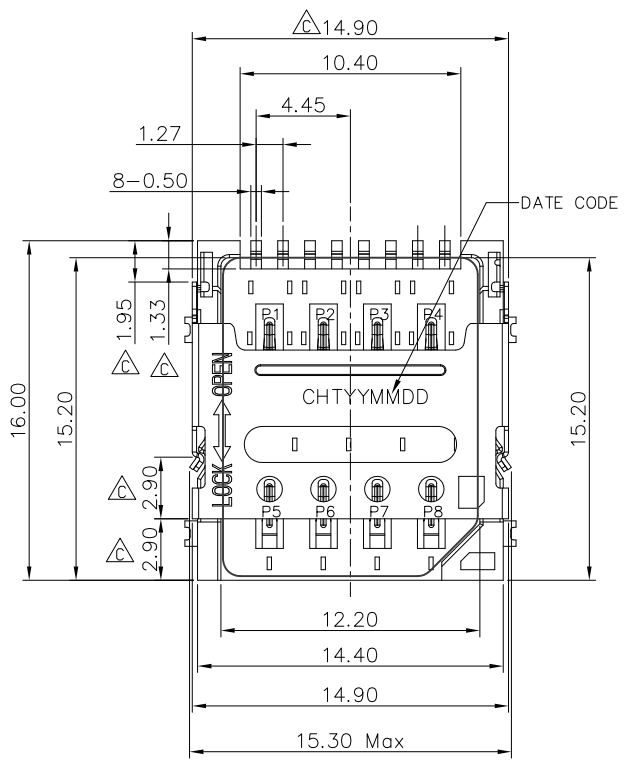
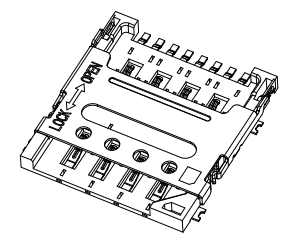
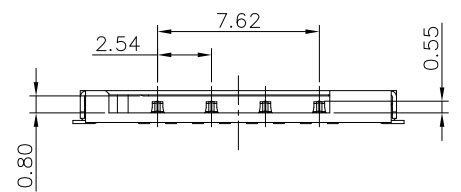

- NOTE:
- MATERIAL:
 - INSULATOR: HIGH TEMPERATURE THERMOPLASTIC, UL94V-0, COLOR: BLACK
 - CONTACT: COPPER ALLOY.
 - SHELL & FORK LOCK : STEEL
 - FINISH:
 - TERMINAL: 50u" MIN. NICKEL PLATED OVERALL
 - CONTACT: SELECTIVE GOLD PLATED, SEE TABLE A
 - TAIL: 100u" MIN MATT-TIN PLATED
 - FORK LOCK : 50u" MIN. NICKEL PLATED OVERALL
 - PRODUCT SPECIFICATION REFER TO SP-A0580-01
 - PACKAGE DRAWING REFER TO PA0580-01
 - PRODUCT MUST CONFORM TO RoHS AND HALOGEN FREE REQUIREMENT

TABLE

FIH P/N	TABLE A GOLD PLATING THICKNESS
A0580-0003	Au30u
A0580-0001	G/F

MICRO SIM CARD	
PIN NO.	DESCRIPTION
C1	VCC
C2	RST
C3	CLK
C4	RESERVED
C5	GND
C6	VPP
C7	I/O
C8	RESERVED

PRODUCT SPECIFICATION: DOC.No: SP-A0580-01	SCALE 1 : 1	DESIGN UNITS mm
TEST REPORT DOC.No: TR-A0580-01	DRAWN Linda	DATE 2019/08/12
GENERAL TOLERANCES (UNLESS SPECIFIED)	CHECKED Mei	DATE 2019/08/12
X.XXX ± 0.10	APPROVED TJ	DATE 2019/08/12
X.XX ± 0.25	ANGULAR ± 3°	
X.X ± 0.38	THIRD ANGLE PROJECTION	DWG NO. SA0580-001

CHT 群匯科技股份有限公司
 CHIUN HUEI Technology CO., LTD.

TITLE
 MICRO SIM CARD CONNECTOR
 HINGE TYPE H=1.5

PART NO. SEE TABLE	DWG REV. C	SHEET NO. 1 OF 1
-----------------------	---------------	---------------------

REVISION HISTORY			
REV	DESCRIPTION	Drawing	DATE
A	PROPOSAL	Mei Chen	2018/04/24

GATHER MATERIAL DIRECTION ← INPUT MATERIAL DIRECTION →

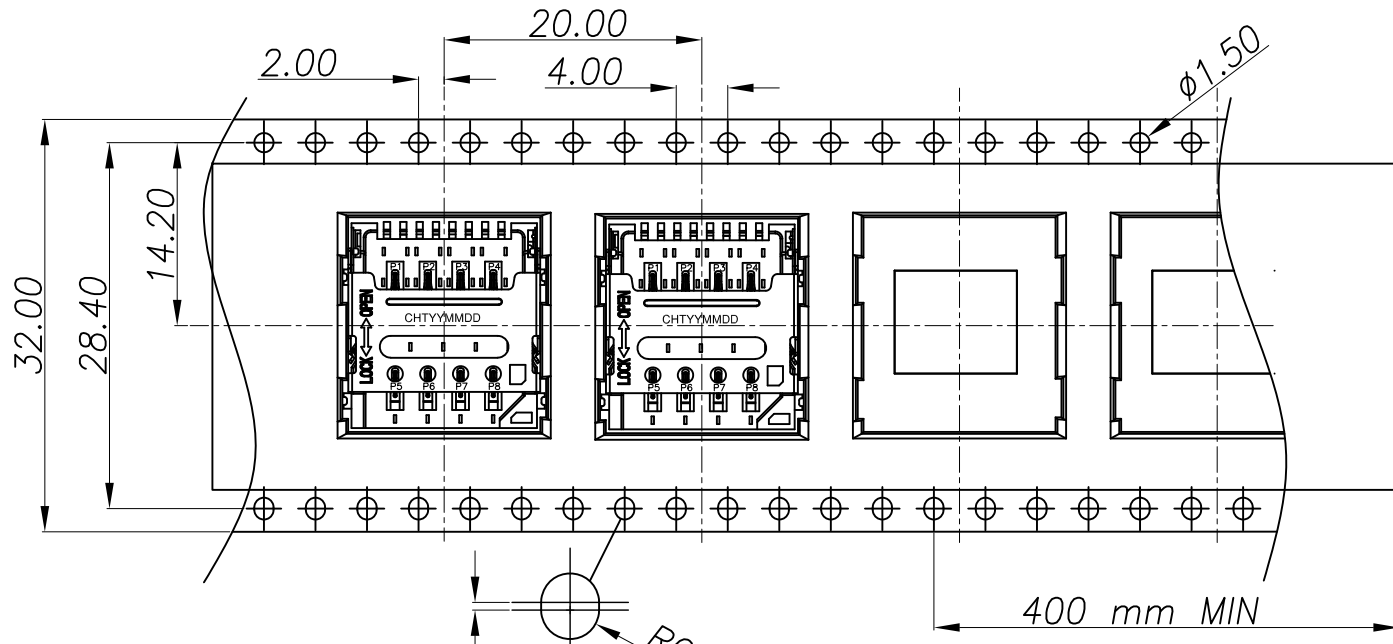

1. COVER TAPE PEELING FORCE:

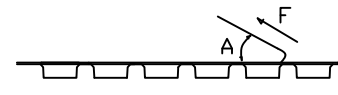

A	15°~ 0°
F	0.1N~1.3N

PEELING SPEED 200MM/MIN

2. PART DIMENSIONS MEET EIA-481-2-A REQUIREMENT

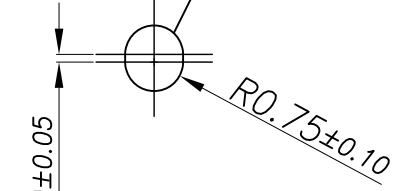
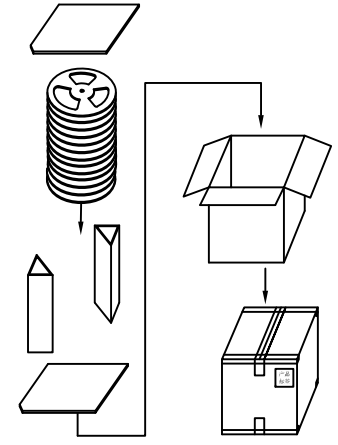

PULL OUT DIRECTION →

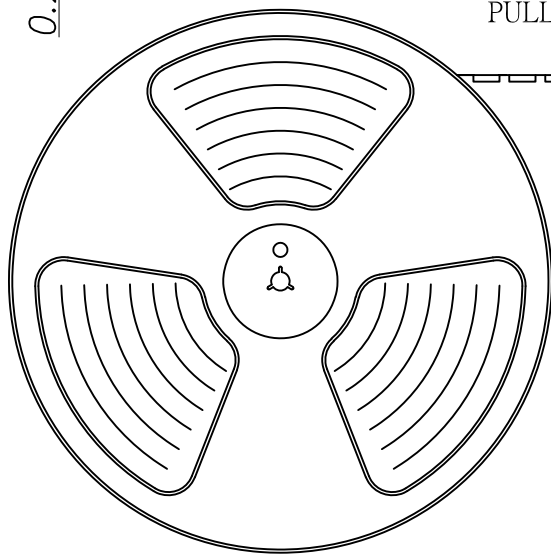
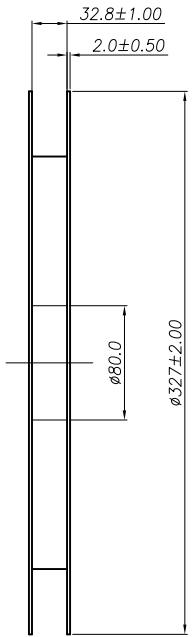

TABLE

PRODUCT P/N	PARTS PER SHIPPING CARTON	PARTS PER REEL (S.P.Q.)	TOTAL REELS PER SHIPPING CARTON
A0580-0003	9600(PCS)	1200(PCS)	8
A0580-0001			

PRODUCT SPECIFICATION: DOC.No: SP-Axxxx-xx	SCALE 1 : 1	DESIGN UNITS mm
TEST REPORT DOC.No: TR-Axxxx-xx	DRAWN Mei Chen	DATE 2018/04/24
GENERAL TOLERANCES (UNLESS SPECIFIED)	CHECKED	DATE
X.XXX ± 0.10	APPROVED	DATE
X.XX ± 0.25	ANGULAR ± 3°	
X.X ± 0.38	THIRD ANGLE PROJECTION	
DWG NO. PA0580-001	PART NO. SEE TABLE	DWG REV. A

CHT 群匯科技股份有限公司
CHIUN HUEI Technology CO., LTD.

TITLE
MICRO SIM CARD CONNECTOR
HINGE TYPE H=1.5

PART NO. SEE TABLE	DWG REV. A	SHEET NO. 1 OF 1
-----------------------	---------------	---------------------