

REVISION HISTORY			
REV	DESCRIPTION	Drawing	DATE
C	客户要求加标注尺寸	Linda	2019/08/14

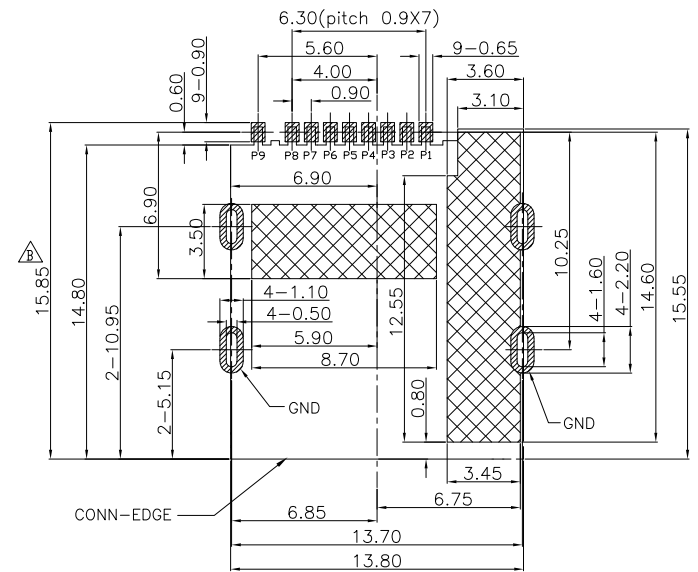

PCB PATTERN LAYOUT  
(GENERAL TOLERANCE:±0.05)

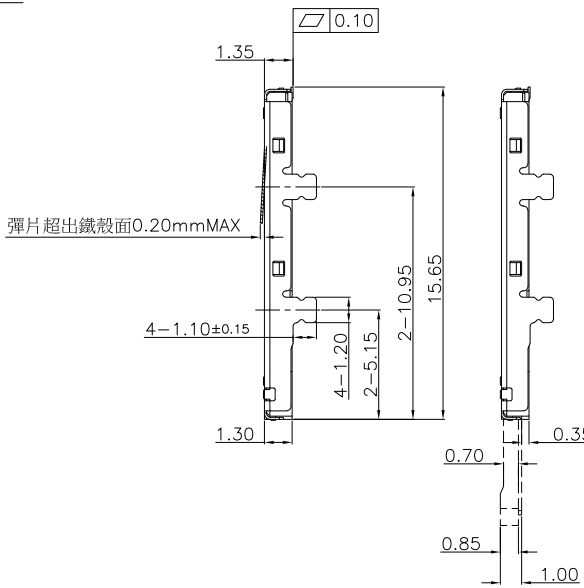
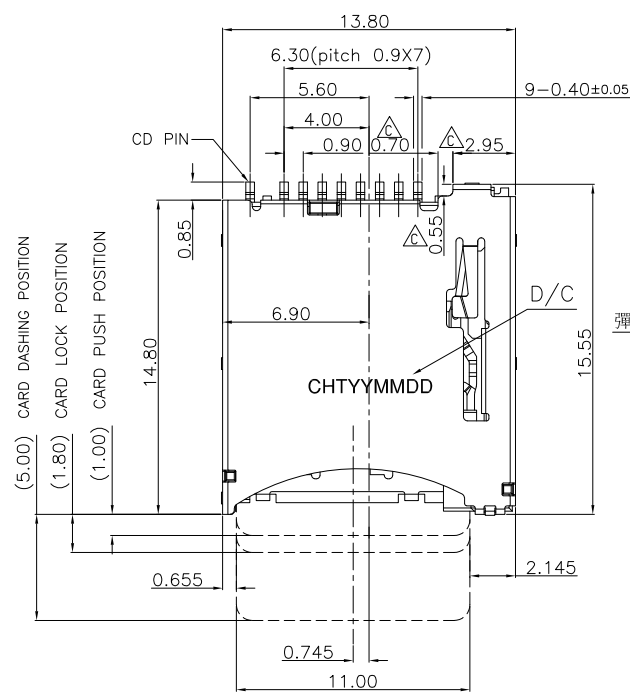
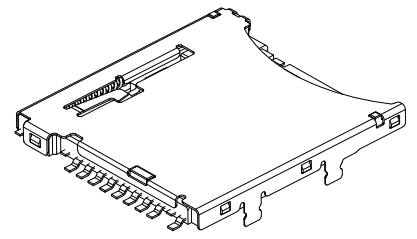
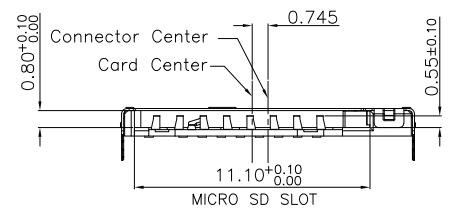

- NOTES:
- MATERIAL:
    - 1.1 PLASTIC: HIGH TEMPERATURE THERMOPLASTIC, UL94V-0, COLOR: BLACK
    - 1.2 CONTACT: COPPER ALLOY
    - 1.3 SHELL: STAINLESS STEEL
  - FINISH:
    - 2.1 TERMINAL: 50u" MIN. NICKEL PLATED OVERALL
    - 2.2 CONTACT: SELECTIVE GOLD PLATED, SEE TABLE A
    - 2.3 TAIL: 80u" MATT-TIN PLATED
    - 2.4 SHELL: 50u" MIN. NICKEL PLATED OVERALL
  - PRODUCT SPECIFICATION REFER TO SP-A0587-01
  - PACKAGE DRAWING REFER TO PA0587-01
  - PRODUCT MUST CONFORM TO RoHS AND HALOGEN FREE REQUIREMENT

Pin Define	
P1	DAT2
P2	CD/DAT3
P3	CMD
P4	VDD
P5	CLK
P6	VSS
P7	DAT0
P8	DAT1
P9	CD PIN

TABLE	
FIH P/N	TABLE A GOLD PLATING THICKNESS
A0587-0003	Au30u
A0587-0001	G/F

PRODUCT SPECIFICATION: DOC.No: SP-AXXX-XX	SCALE 1 : 1	DESIGN UNITS mm
TEST REPRDT DOC.No: TR-AXXX-XX	DRAWN Linda	DATE 2019/08/14
GENERAL TOLERANCES (UNLESS SPECIFIED)	CHECKED Mei	DATE 2019/08/15
X.XXX ± 0.10	APPROVED TJ	DATE 2019/08/15
X.XX ± 0.25	DWG NO. SA0587-001	
X.X ± 0.38		
ANGULAR ± 3°		
THIRD ANGLE PROJECTION		

**CHT** 群匯科技股份有限公司  
CHUIN HUEI Technology CO., LTD.

TITLE  
Micro SD Push Push Connector  
Top-Mount,H=1.35

PART NO. TABLE A	DWG REV. C	SHEET NO. 1 OF 1
---------------------	---------------	---------------------

REVISION HISTORY			
REV	DESCRIPTION	Drawing	DATE
A	RELEASE	Sandy	2018/10/30

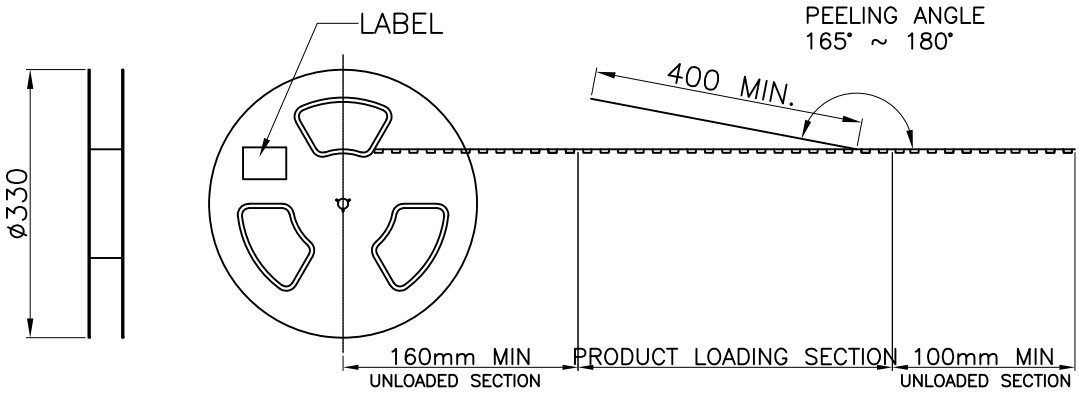
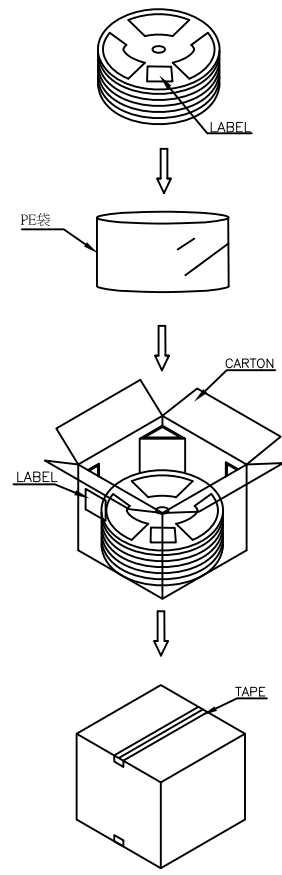
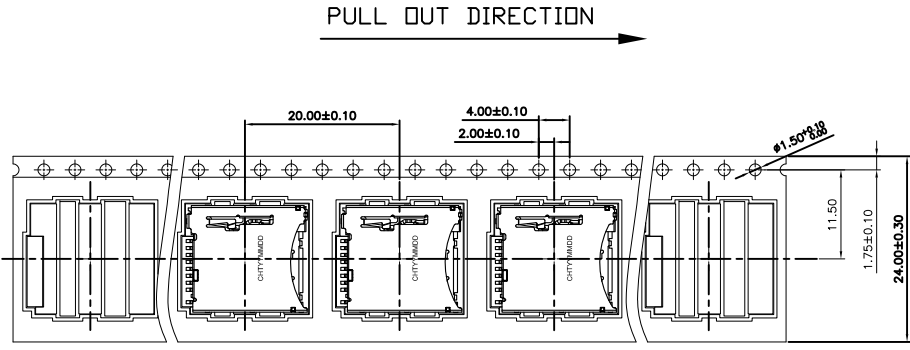

1.COVER TAPE PEELING FORCE:

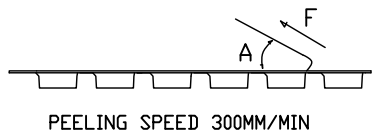

A	15° ~ 0°
F	0.1N ~ 1.3N

PEELING SPEED 300MM/MIN

2.PART DIMENSIONS MEET EIA-481-D REQUIREMENT

PRODUCT P/N	PARTS PER SHIPPING CARTON	PARTS PER REEL (S.P.Q.)	TOTAL REELS PER SHIPPING CARTON
A0587-0001	1000(PCS)	1000(PCS)	10
A0587-0003			
PRODUCT SPECIFICATION: DDC.No: SP-Axxxx-xx TEST REPORT DDC.No: TR-Axxxx-xx GENERAL TOLERANCES (UNLESS SPECIFIED)		SCALE 1 : 1	DESIGN UNITS mm
X.XXX ± 0.10 X.XX ± 0.25 X.X ± 0.38 ANGULAR ± 3°		DRAWN Mei Chen	DATE 2018/05/29
THIRD ANGLE PROJECTION		CHECKED DATE	TITLE Micro SD Push Push Connector Top-Mount,H=1.35
DWG NO. PA0587-001		PART NO. SEE TABLE	DWG REV. A
		SHEET NO. 1 OF 1	

**CHT** 群匯科技股份有限公司  
 CHIUN HUEI Technology CO., LTD.