

HF

REVISION HISTORY

REV	DESCRIPTION	Drawing	DATE
01	PROPOSAL	Mei Chen	2014/10/30
02	PROPOSAL	Mei Chen	2014/11/25
03	PROPOSAL	Mei Chen	2015/01/20
04	PROPOSAL	Mei Chen	2015/01/26

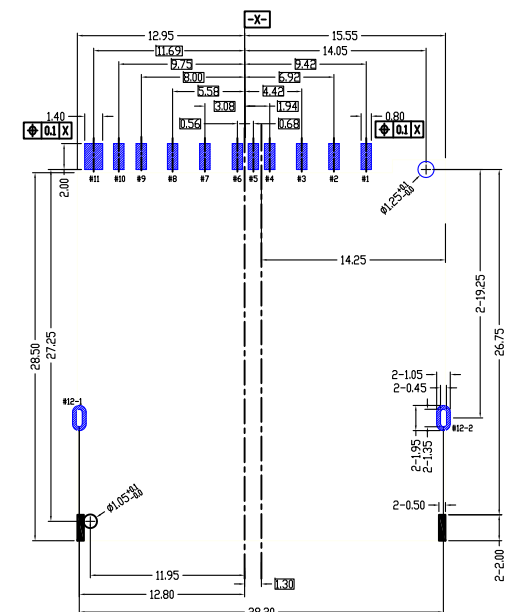
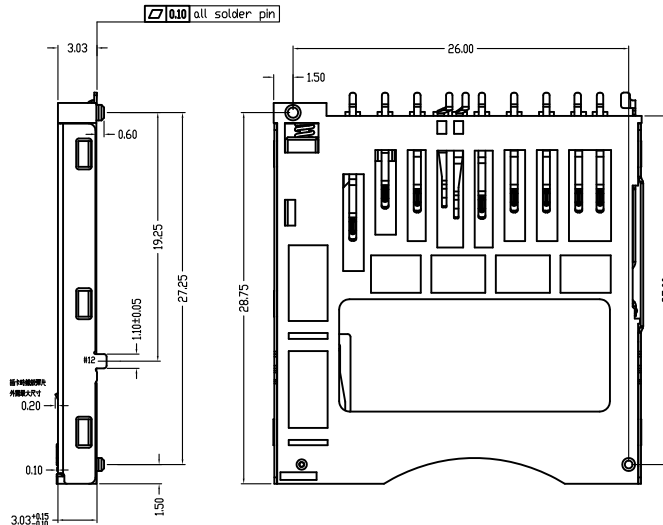
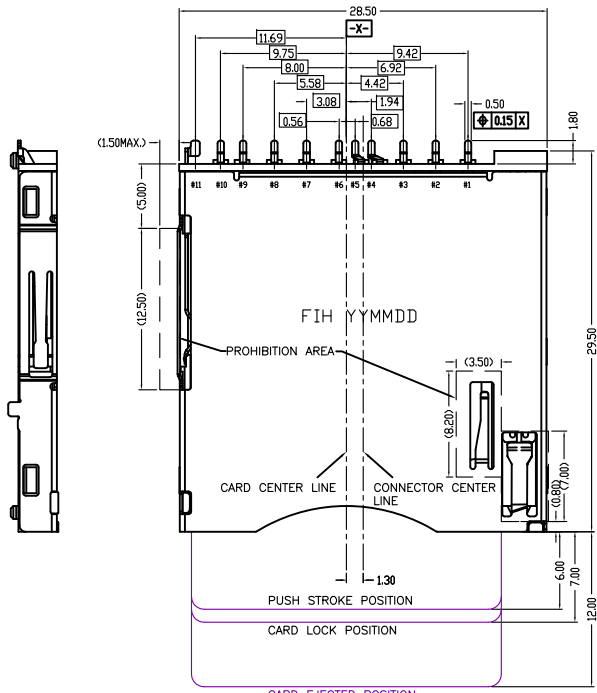

RECOMMEND P.C.B LAYOUT
GENERAL TOLERANCE ±0.05

There should not be any circuitries in the layout space of the PCB type products.

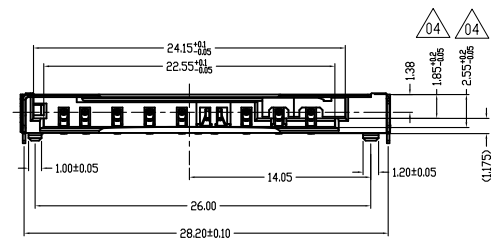

Pin Define

PIN NO.	NAME
#1	DAT2
#2	DAT3
#3	CMD
#4	C/D
#5	Vss 1
#6	VDD
#7	CLK
#8	Vss 2
#9	DAT0
#10	DAT1
#11	W/P
#12-1	GND
#12-2	GND

WITHOUT CARD	CARD INSERTED:LOCK	CARD INSERTED:UNLOCK
W/P #11 GND #12	W/P #11 GND #12	W/P #11 GND #12
C/D #04 VSS1 #05	C/D #04 VSS1 #05	C/D #04 VSS1 #05

FIH P/N	GOLD THICKNESS
A0305-0001	G/F Au
A0305-0003	30u" Au

No.	DESCRIPTION	Q'TY	MATERIAL	PLATING & COLOR
6	W/P CONTACT	1	C5210-SH	GOLD PLATED/ MATTE-Tin
5	CRANK	1	SUS304	N/A
4	SPRING	1	SWPB	NICKEL PLATING
3	TERMINAL	10	C5210-SH	SEE TABLE
2	HOUSING	2	LCP MG350	UL94 V-0(BLACK)
1	SHELL	1	SUS304-3/4H	50μ" NICKEL PLATING

PRODUCT SPECIFICATION: DOC.No. SP-Axxxx-xx	SCALE 1 : 1	DESIGN UNITS mm
TEST REPORT DOC.No. TR-Axxxx-xx	DRAWN Mei Chen	DATE 2014/10/30
GENERAL TOLERANCES (UNLESS SPECIFIED)	CHECKED	DATE
X.XXX ± 0.20	APPROVED	DATE
X.XX ± 0.20	DWG NO. SA0305-001	
X.X ± 0.25		
ANGULAR ± 3°		
THIRD ANGLE PROJECTION		

FULLINHOPE Technology, LTD.		
TITLE		
SD CARD SLOT CONNECTOR TOP DIP TYPE H=3.03mm		
PART NO. SEE TABLE	DWG REV. 04	SHEET NO. 1 OF 1

HF

REVISION HISTORY

REV	DESCRIPTION	Drawing	DATE
01	PROPORSAL	Mei Chen	2014/10/30
02	PROPORSAL	Mei Chen	2014/11/25

GATHER MATERIAL DIRECTION INPUT MATERIAL DIRECTION

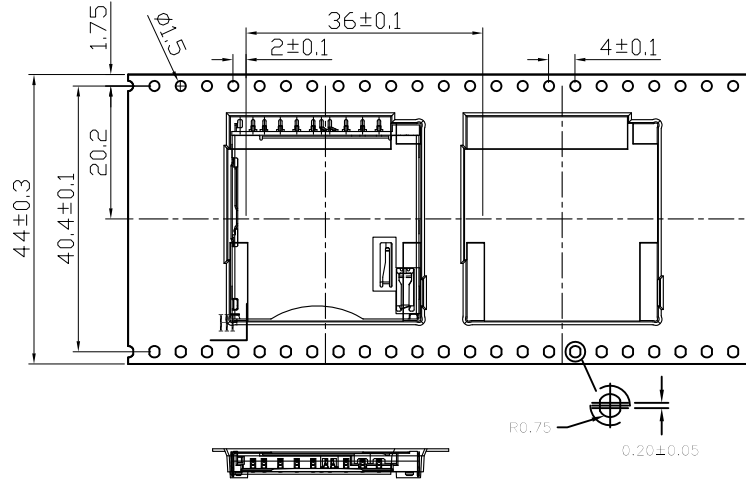

1. COVER TAPE PEELING FORCE:

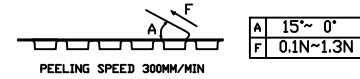

2. PART DIMENSIONS MEET EIA-481-2-A REQUIREMENT

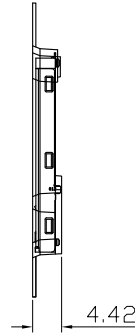

TAIL PART
(5pcs EMPTY)
(180MM)

CONNECTOR PACKING AREA

LADER PART
(5pcs EMPTY)
(180MM)

COVER TAPE

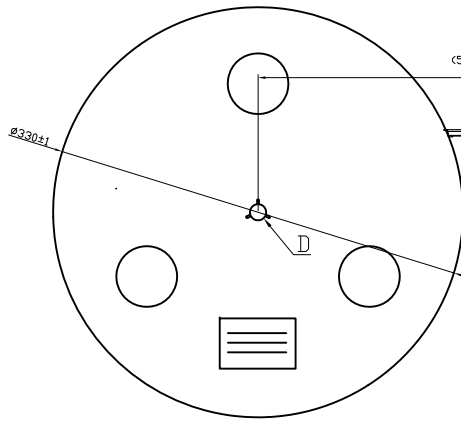

PULL OUT DIRECTION

TABLE Δ_2

PRODUCT P/N	PARTS PER SHIPPING CARTON	PARTS PER REEL (S.P.Q.)	TOTAL REELS PER SHIPPING CARTON
A0305-0001(G/F)	2000(PCS)	400(PCS)	5
A0305-0003(30u')	2000(PCS)	400(PCS)	5

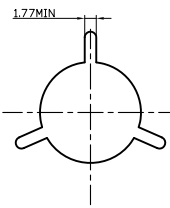

PRODUCT SPECIFICATION: DOC.No. SP-Axxxx-xx	SCALE 1 : 1	DESIGN UNITS mm	FULLINHOPE Technology, LTD.	
TEST REPORT DOC.No. TR-Axxxx-xx	DRAWN Mei Chen	DATE 2014/10/30	TITLE SD CARD SLOT CONNECTOR TOP DIP TYPE H=3.03mm	
GENERAL TOLERANCES (UNLESS SPECIFIED)	CHECKED	DATE		
X.XXX ± 0.20	APPROVED	DATE		
X.XX ± 0.20				
X.X ± 0.25				
ANGULAR ± 3°				
THIRD ANGLE PROJECTION	DWG NO. PA0305-001	PART NO. SEE TABLE	DWG REV. 02	SHEET NO. 1 OF 1