

REVISION HISTORY			
REV	DESCRIPTION	Drawing	DATE
A	RELEASE	Josephine Lin	2013/07/03
B	RELEASE	Mei Chen	2013/11/19
C	RELEASE	Mei Chen	2014/01/09

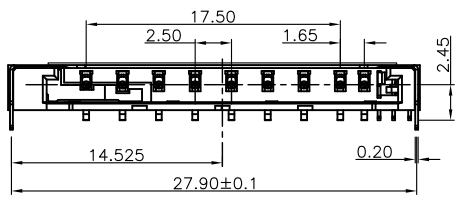
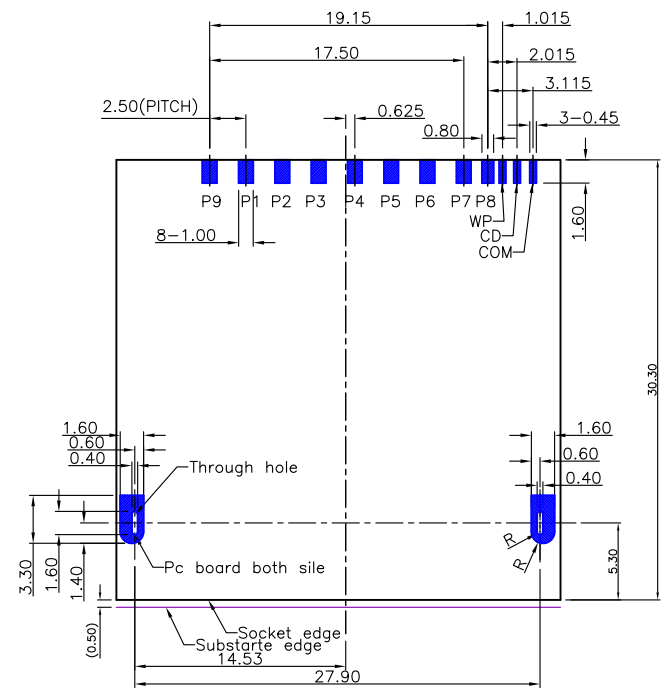
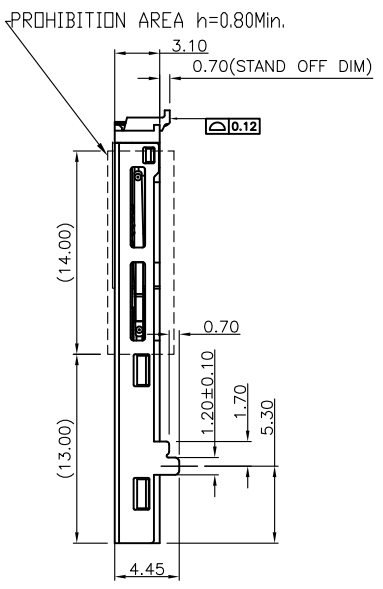
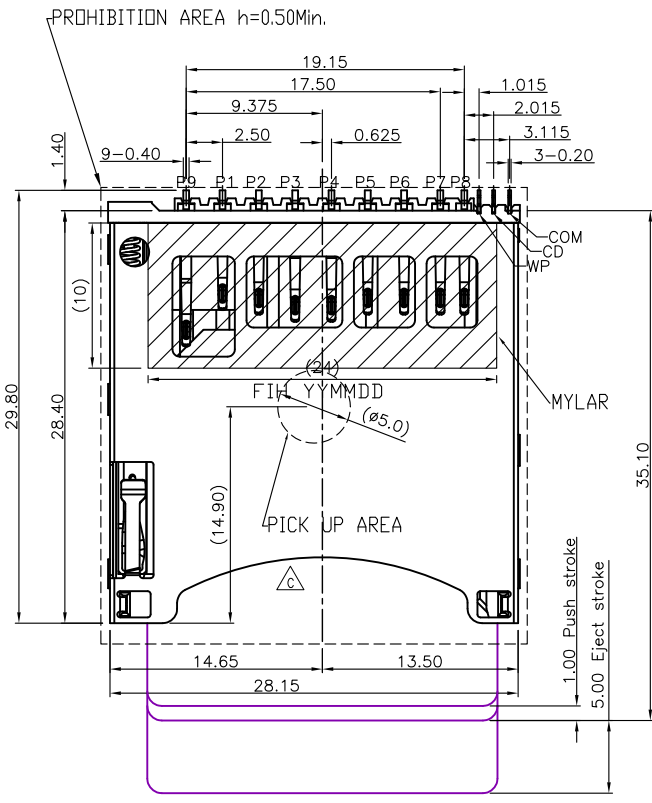

NOTES:

- MATERIAL:
 - HOUSING: LCP E6808, UL94 V-0 , COLOR: BLACK.
 - CONTACT: C5210
 - SHELL: SUS304
 - W.P./COM/CD: C5210
 - CRANK: SUS304
 - SPRING: SWPB.
 - Mylar: PI, Color: Amber
- PLATING:
 - CONTACT/W.P./COM/CD: GOLD FLASH ON CONTACT AREA
100 μ MIN. MATTE-TIN ON SOLDERING TAILS
50 μ MIN. NICKEL UNDERPLATING OVER ALL
 - SHELL: 50 μ MIN. NICKEL UNDERPLATING OVER ALL
- PACKAGING DRAWING REFER TO PA0151-001
- DATE:YY(YEAR),MM(MONTH),DD(DDATE).

RECOMMEND P.C.B LAYOUT
GENERAL TOLERANCE ± 0.05

PIN NO.	SD NAME	MMC NAME
P1	CD/DAT3	RSV
P2	CMD	CMD
P3	VSS	VSS
P4	VDD	VDD
P5	CLK	CLK
P6	VSS	VSS
P7	DAT0	DAT
P8	DAT1	
P9	DAT2	

WITHOUT CARD	CD CD/WP COM
	WP CD/WP COM
INSERTED CARD(UNLOCK)	CD CD/WP COM
	WP CD/WP COM
INSERTED CARD(LOCK)	CD CD/WP COM
	WP CD/WP COM

PRODUCT SPECIFICATION: DOC.No: SP-A0119-01	SCALE 1 : 1	DESIGN UNITS mm	FULLINHOPE Technology, LTD.	
TEST REPORT DOC.No: TR-A0151-01	DRAWN Josephine Lin	DATE 2013/07/03	TITLE SD CARD P/P TYPE REVERSE	
GENERAL TOLERANCES (UNLESS SPECIFIED)	CHECKED	DATE		
X.XXX ± 0.20	APPROVED	DATE		
X.XX ± 0.20				
X.X ± 0.25				
ANGULAR $\pm 3^\circ$	DWG NO. SA0151-001	PART NO. A0151-0001	DWG REV. C	SHEET NO. 1 OF 1
THIRD ANGLE PROJECTION				

REVISION HISTORY			
REV	DESCRIPTION	Drawing	DATE
A	RELEASE	Mei Chen	2013/08/20

PULL OUT DIRECTION

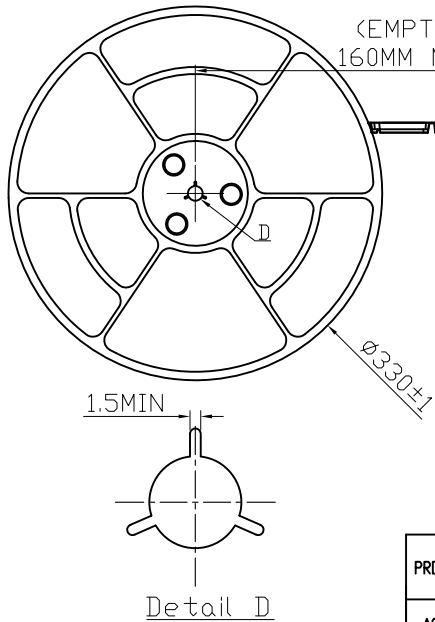
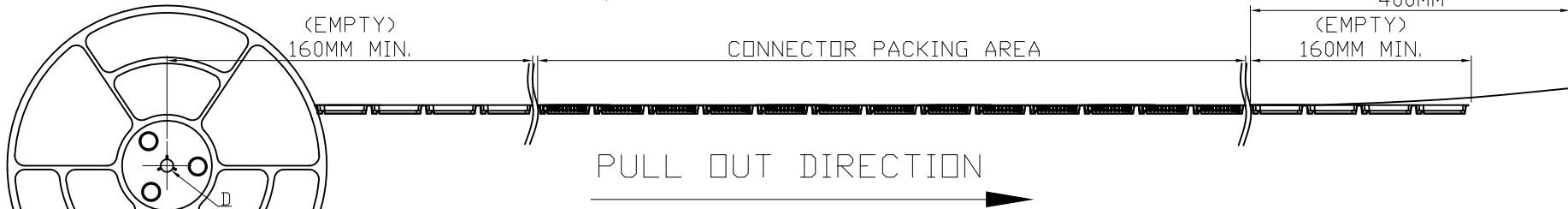
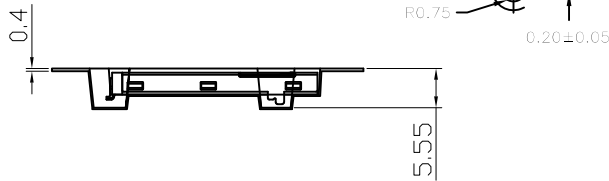
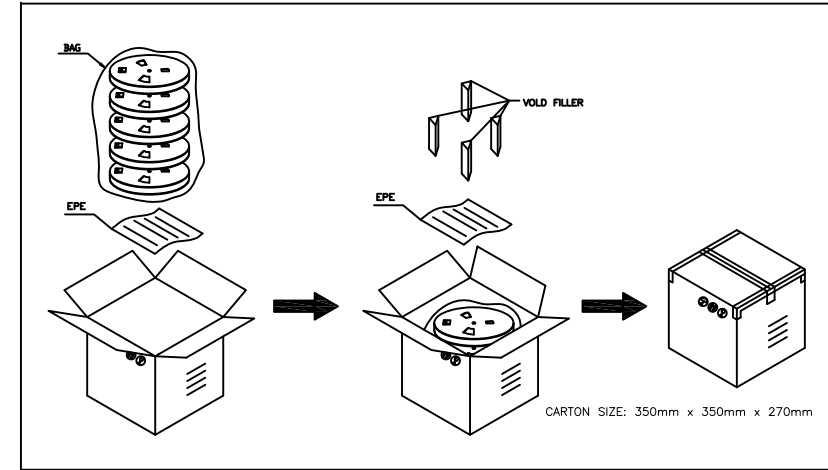
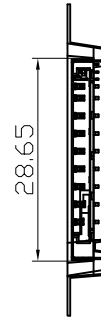
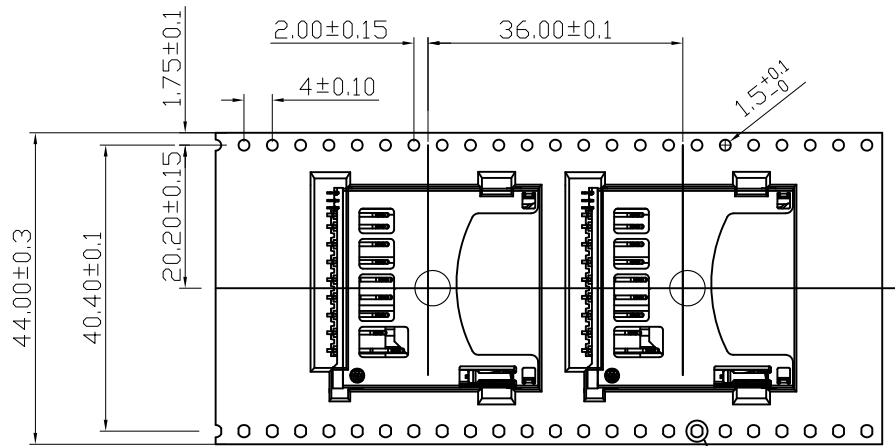

1. COVER TAPE PEELING FORCE:

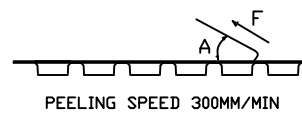

A	15°~ 0°
F	0.1N~1.3N

2. PART DIMENSIONS MEET EIA-481-2-A REQUIREMENT

PRODUCT P/N	PARTS PER SHIPPING CARTON	PARTS PER REEL (S.P.Q.)	TOTAL REELS PER SHIPPING CARTON
A0151-0001	1500(PCs)	300(PCs)	5

PRODUCT SPECIFICATION: DDC.No: SP-Axxxx-xx	SCALE 1 : 1	DESIGN UNITS mm
TEST REPORT DDC.No: TR-Axxxx-xx	DRAWN Josephine Lin	DATE 2013/07/02
GENERAL TOLERANCES (UNLESS SPECIFIED)	CHECKED	DATE
X.XXX ± 0.20	APPROVED	DATE
X.XX ± 0.20		
X.X ± 0.25		
ANGULAR ± 3°		



DWG NO. PA0151-001	PART NO. A0151-0001	DWG REV. A	SHEET NO. 1 OF 1
-----------------------	------------------------	---------------	---------------------

FULLINHOPE Technology, LTD.	
TITLE SD CARD P/P TYPE REVERSE	