

REVISION HISTORY			
REV	DESCRIPTION	Drawing	DATE
01	PROPOSAL	Mei Chen	2019/05/15

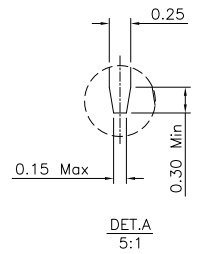
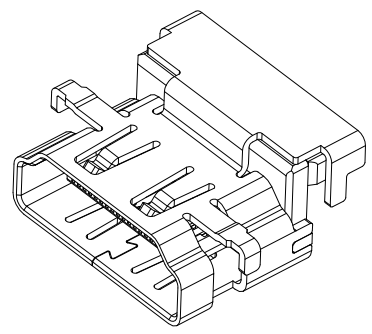
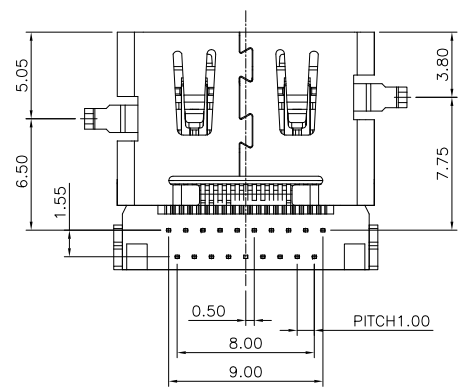
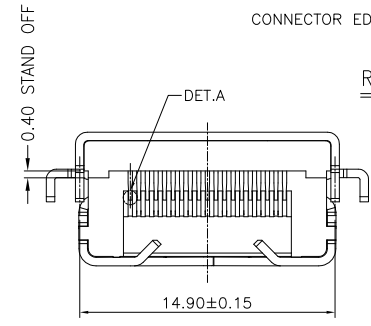
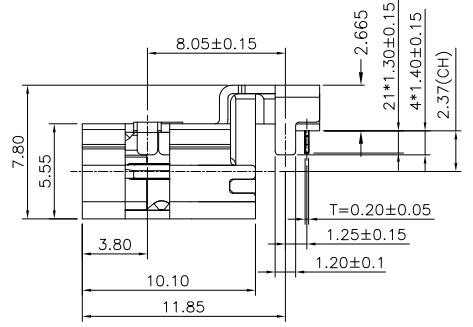
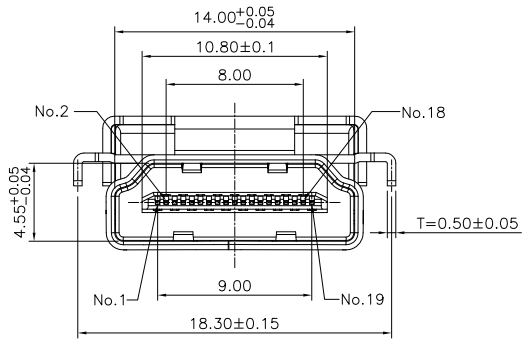
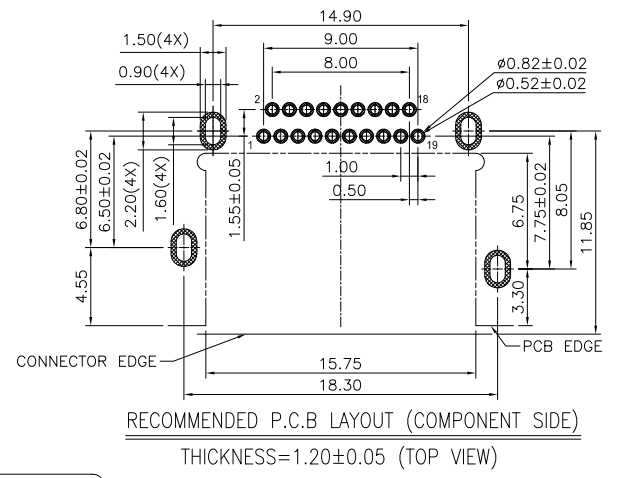
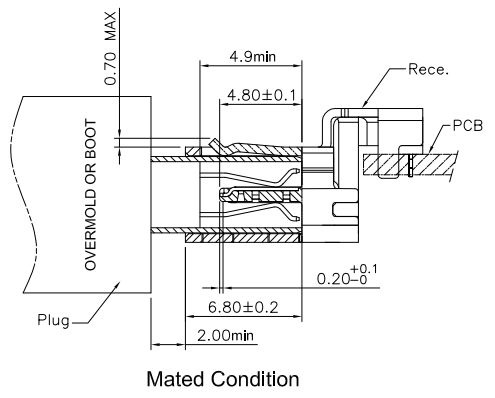
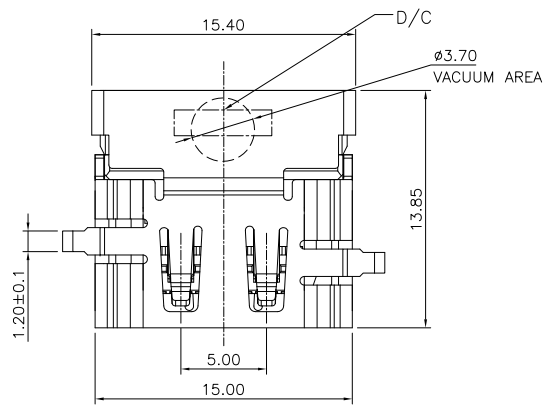

- NOTES:
- MATERIAL:
 - 1.1 PLASTIC: LCP , UL 94V-0, COLOR: BLACK
 - 1.2 CONTACT: C5191
 - 1.3 SHELL: SK7
 - FINISH:
 - 2.1 TERMINAL: 50u" MIN. NICKEL PLATED OVERALL
 - 2.2 CONTACT: SELECTIVE GOLD PLATED, SEE TABLE A
 - 2.3 TAIL: 100u" MATT-TIN PLATED
 - 2.4 SHELL: 50u" MIN. NICKEL PLATED OVERALL
 - PRODUCT SPECIFICATION REFER TO SP-A0719-01
 - PACKAGE DRAWING REFER TO PA0719-01
 - PRODUCT MUST CONFORM TO RoHS AND HALOGEN FREE REQUIREMENT
 - DATE CODE: XX (YEAR), XX (MONTH) ,XX (DATE)

FIH P/N	TABLE A GOLD PLATING THICKNESS
A0719-0003	Au30u
A0719-0001	G/F

PRODUCT SPECIFICATION: DOC.No: SP-AXXXX-XX	SCALE 1 : 1	DESIGN UNITS mm
TEST REPORT DOC.No: TR-AXXXX-XX	DRAWN Mei Chen	DATE 2019/05/15
GENERAL TOLERANCES (UNLESS SPECIFIED)	CHECKED	DATE
X.XXX ± 0.10		
X.XX ± 0.15		
X.X ± 0.20	APPROVED	DATE
ANGULAR ± 3°	DWG NO. SA0719-001	
THIRD ANGLE PROJECTION		

FULLINHOPE Technology, LTD.

TITLE: HDMI AF R/A DIP RVS TYPE
CH=-2.37

PART NO. TABLE A	DWG REV. 01	SHEET NO. 1 OF 1
------------------	-------------	------------------

REVISION HISTORY			
REV	DESCRIPTION	Drawing	DATE
01	PROPOSAL	Mei Chen	2019/05/15

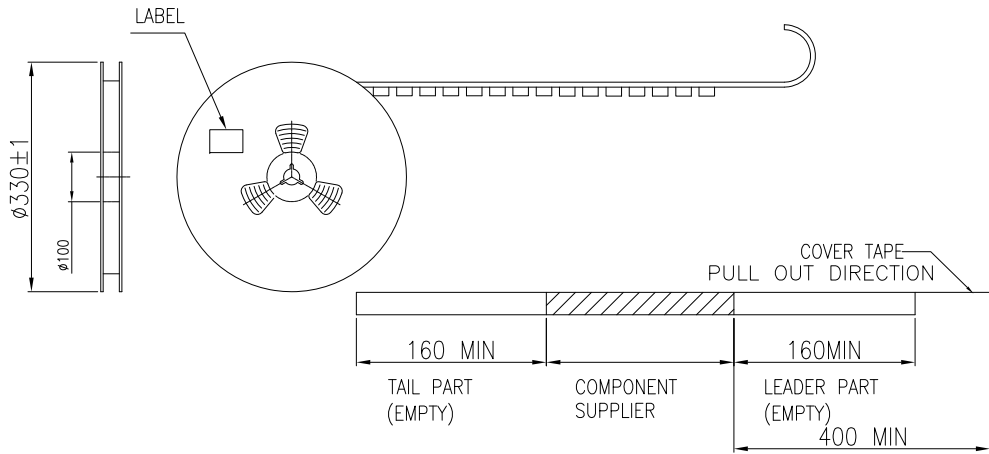
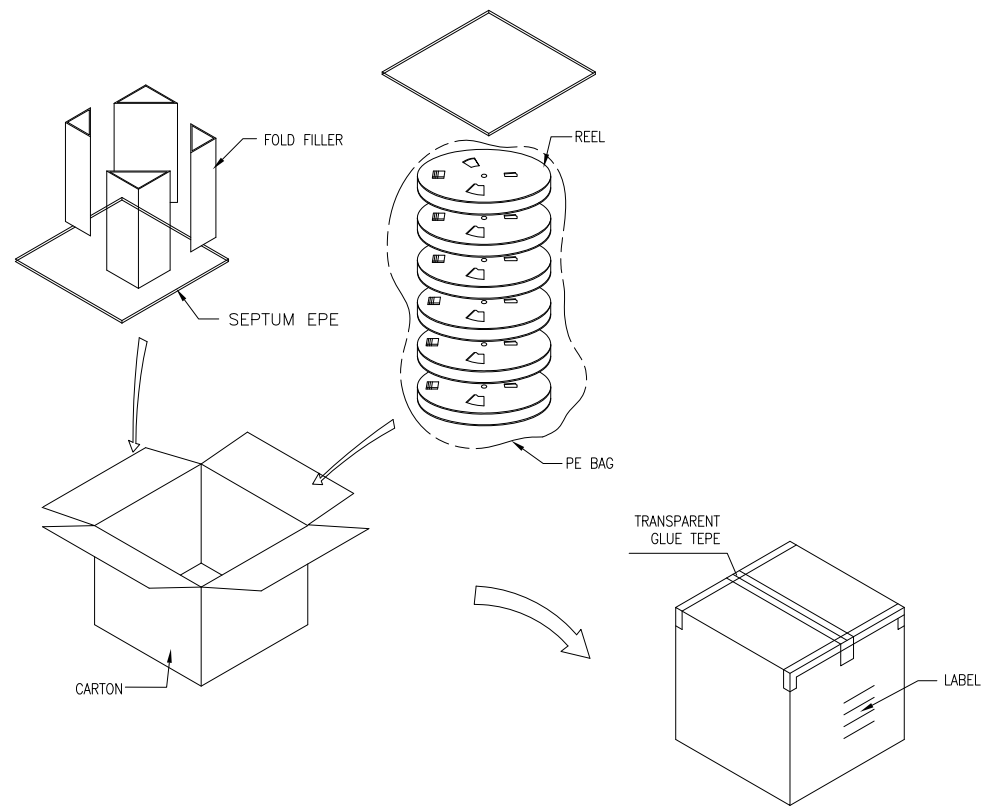
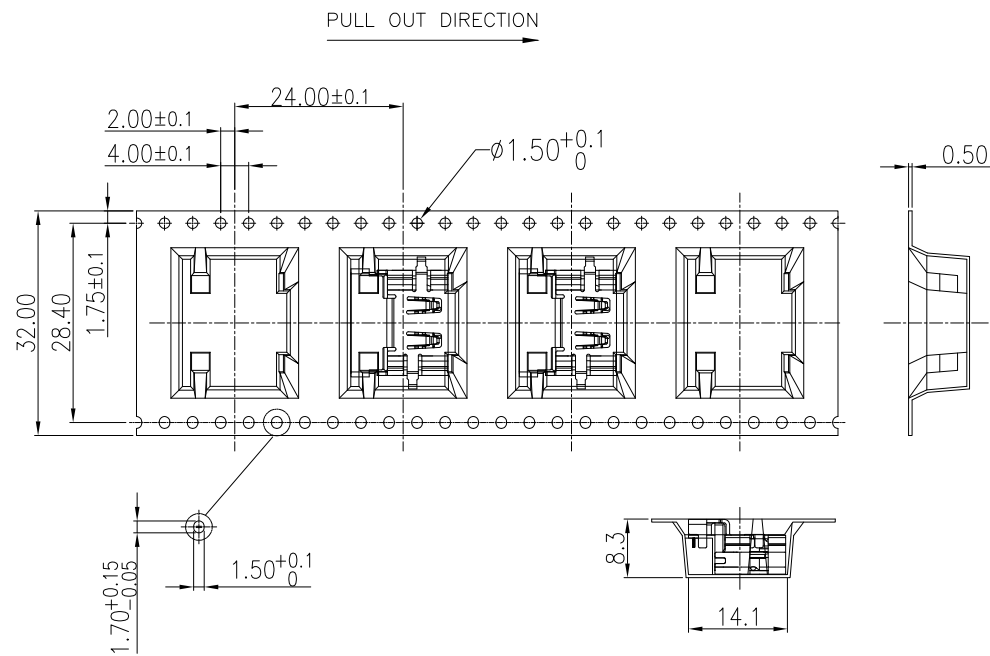

1. COVER TAPE PEELING FORCE:

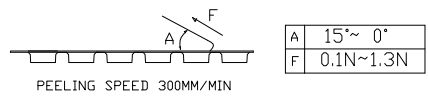

2. PART DIMENSIONS MEET EIA-481-2-A REQUIREMENT

TABLE

PRODUCT P/N	PARTS PER SHIPPING CARTON	PARTS PER REEL	LOADED REEL PER SHIPPING CARTON
A0719-0003	3000	300	10
A0719-0001			

PRODUCT SPECIFICATION: DOC.No: SP-AXXXX-001	SCALE 1 : 1	DESIGN UNITS mm	FULLINHOPE Technology, LTD.	
TEST REPRDT DOC.No: TR-AXXXX-001	DRAWN Mei Chen	DATE 2019/05/15	TITLE HDMI AF R/A DIP RVS TYPE CH= -2.37	
GENERAL TOLERANCES (UNLESS SPECIFIED)	CHECKED	DATE		
X.XXX ± 0.20	APPROVED	DATE		
X.XX ± 0.20				
XX ± 0.25				
ANGULAR ± 3°				
THIRD ANGLE PROJECTION	DWG NO. PA0719-001	PART NO. SEE TABLE	DWG REV. 01	SHEET NO. 1 OF 1