

REV	DESCRIPTION	Drawing	DATE
07	新增尺寸标注	Allen	2020/03/20

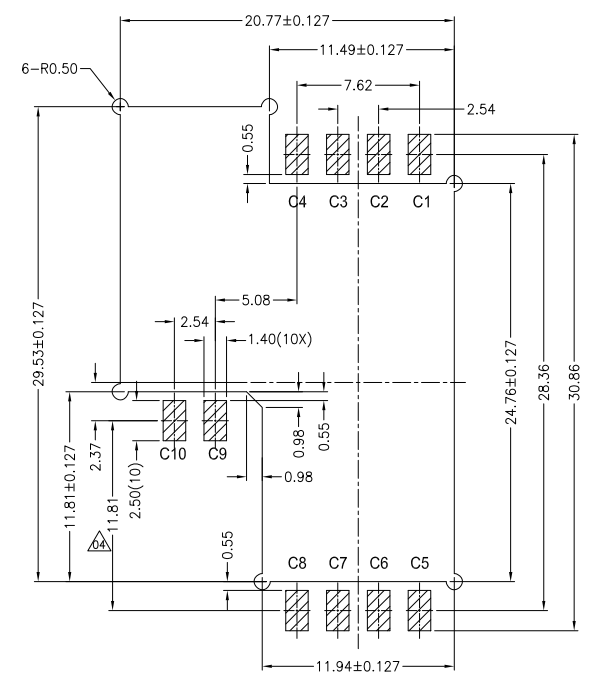

RECOMMENDED PCB LAYOUT (TOP VIEW)  
GENERAL TOLERANCES: ±0.05 (t=0.6)

- NOTE:
- MATERIAL:
    - INSULATOR: LCP+30%G.F,UL94V-0,Black
    - CONTACT: C5191
  - FINISH:
    - TERMINAL: 40u" MIN. NICKEL PLATED OVERALL
    - CONTACT: SEE TABLE
    - TAIL: 100u" MIN MATT-TIN PLATED
  - PRODUCT SPECIFICATION REFER TO SP-A0784-01
  - PACKAGE DRAWING REFER TO PA0784-01
  - PRODUCT MUST CONFORM TO RoHS AND HALOGEN FREE REQUIREMENT
  - MECHANICAL CHARACTERISTIC
    - Contact Force: 0.2Nf-0.6Nf.
    - Durability: 100,000 Cycles.
  - ELECTRICAL CHARACTERISTIC
    - Current Rating: 10uA Min, 1.0A Max.
    - Voltage Rating: 30V AC.
    - Contact Resistance: 100m Ohm Max.
    - Insulation Resistance: 1000M Ohm Min
    - Dielectric Withstanding Voltage: 500V AC Min
  - TEMPERATURE
    - Operating Temperature: -40°C~+85°C
    - Storage Temperature: -60°C~+105°C

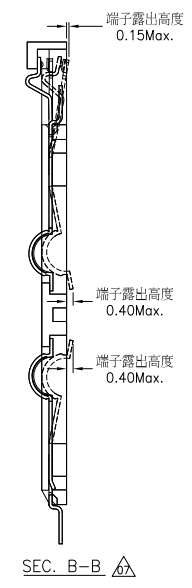
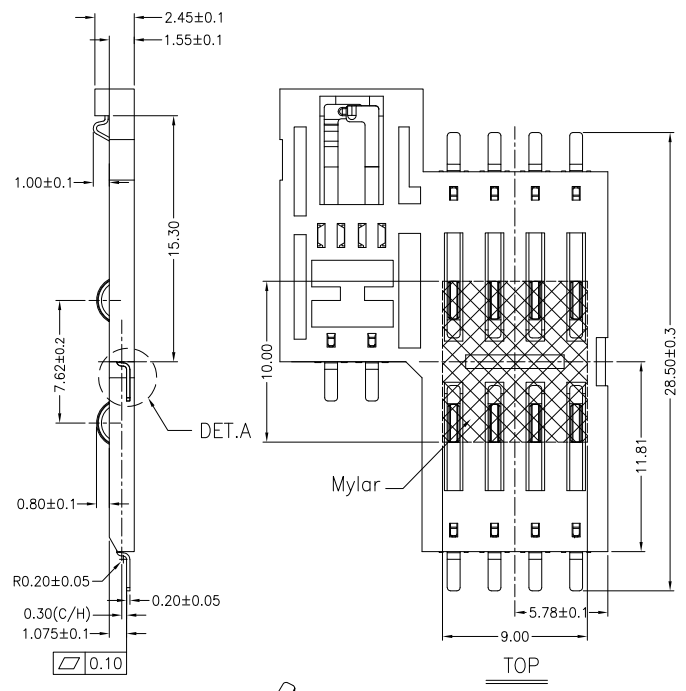
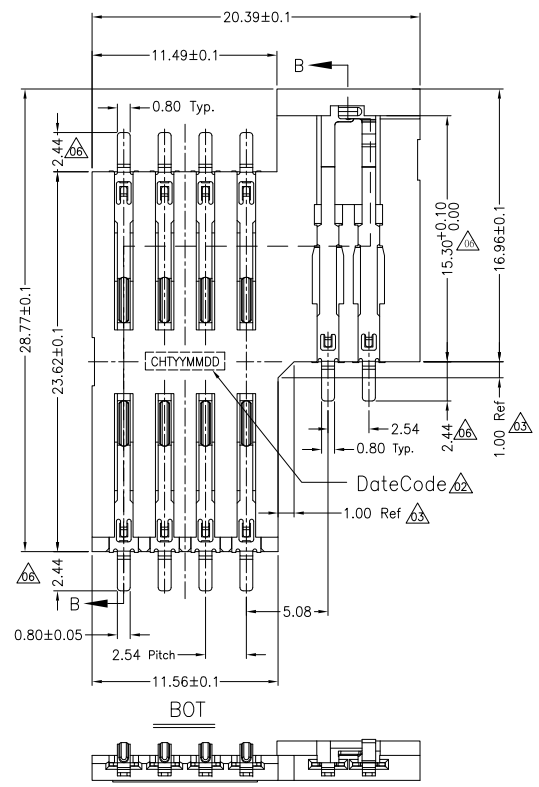
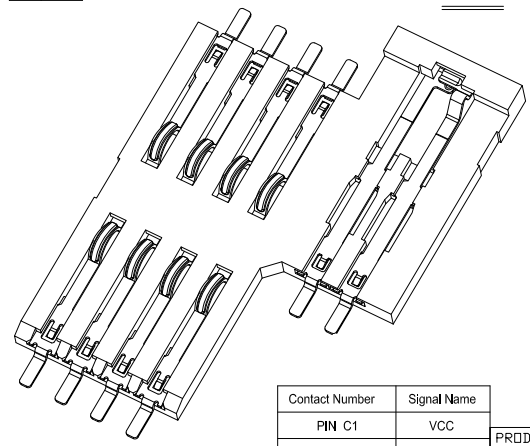

Contact Number	Signal Name
PIN C1	VCC
PIN C2	RST
PIN C3	CLK
PIN C4	C4
PIN C5	GND
PIN C6	VPP
PIN C7	IO
PIN C8	C8
PIN C9	SW-CD-GND
PIN C10	SW-CD

FIH P/N	TABLE A GOLD PLATING THICKNESS
A0784-0003	Au 30u"
A0784-0001	G/F
A0784-3003	GOLD PLATED 30u" 专用

PRODUCT SPECIFICATION: DOC.No. SP-A0784-01	SCALE 1:1	DESIGN UNITS mm
TEST REPORT DOC.No. TR-A0784-01	DRAWN Allen	DATE 2019/12/17
GENERAL TOLERANCES (UNLESS SPECIFIED)	CHECKED	DATE
X.XXX ± 0.10	APPROVED	DATE
X.XX ± 0.25	DWG NO. SA0784-001	
X.X ± 0.38		
ANGULAR ± 3°		
THIRD ANGLE PROJECTION		

**CHT 群匯科技股份有限公司**  
CHIUN HUEI Technology CO., LTD.

TITLE: SMART CARD SOCKET  
PRODUCT H=1.075

PART NO. SEE TABLE	DWG REV. 07	SHEET NO. 1 OF 1
--------------------	-------------	------------------

REVISION HISTORY			
REV	DESCRIPTION	Drawing	DATE
03	尺寸 & 包裝數量 變更	Allen	2020/08/04

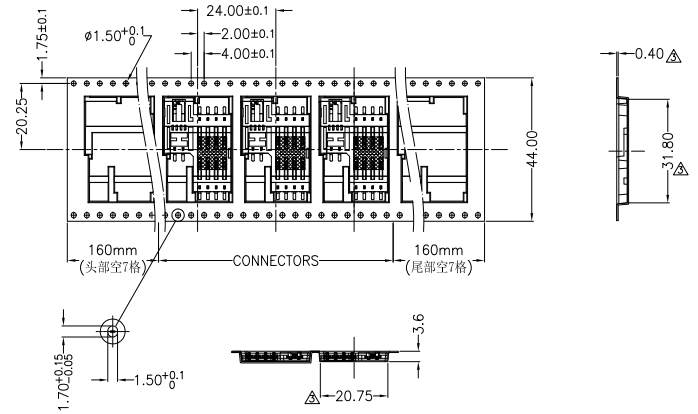
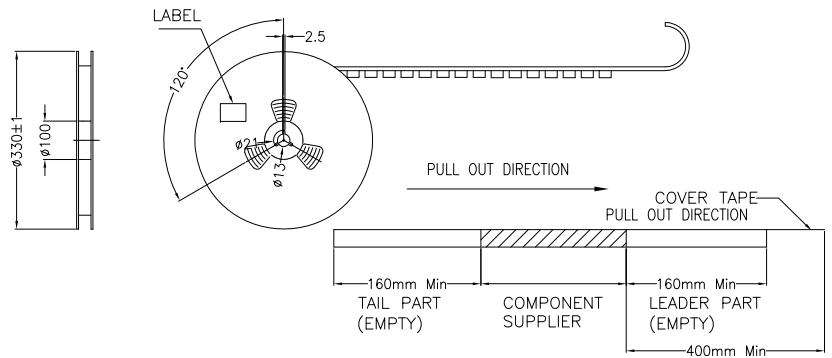
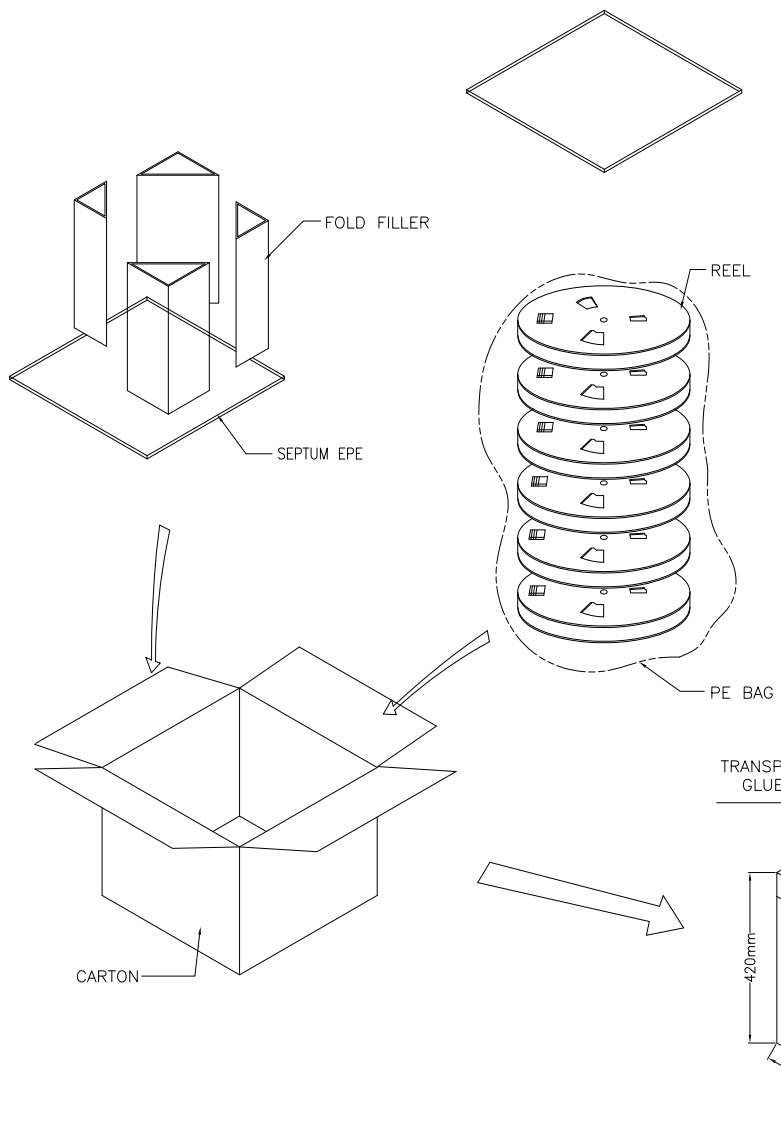

TABLE

PRODUCT P/N	PARTS PER SHIPPING CARTON	PARTS PER REEL	LOADED REEL PER SHIPPING CARTON
A0784-0003	△	△	8
A0784-0001	5600	700	8
A0784-3003			

1. COVER TAPE PEELING FORCE:

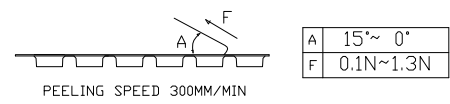

2. PART DIMENSIONS MEET EIA-481-2-A REQUIREMENT

PRODUCT SPECIFICATION: DDC.No. SP-AXXXX-XX	SCALE 1 : 1	DESIGN UNITS mm
TEST REPORT DDC.No. TR-AXXXX-XX	DRAWN Allen	DATE 2019/12/17
GENERAL TOLERANCES (UNLESS SPECIFIED)	CHECKED	DATE
X.XXX ± 0.10	APPROVED	DATE
X.XX ± 0.25	DWG NO. PA0784-001	PART NO. SEE TABLE
X.X ± 0.38		DWG REV. 03
ANGULAR ± 3°		SHEET NO. 1 OF 1
THIRD ANGLE PROJECTION		

**CHT** 群匯科技股份有限公司  
CHIUN HUEI Technology CO., LTD.

TITLE  
SMART CARD SOCKET  
PRODUCT, H=1.075