

REVISION HISTORY			
REV	DESCRIPTION	Drawing	DATE
02	修改電鍍規格	Allen	2020/01/03

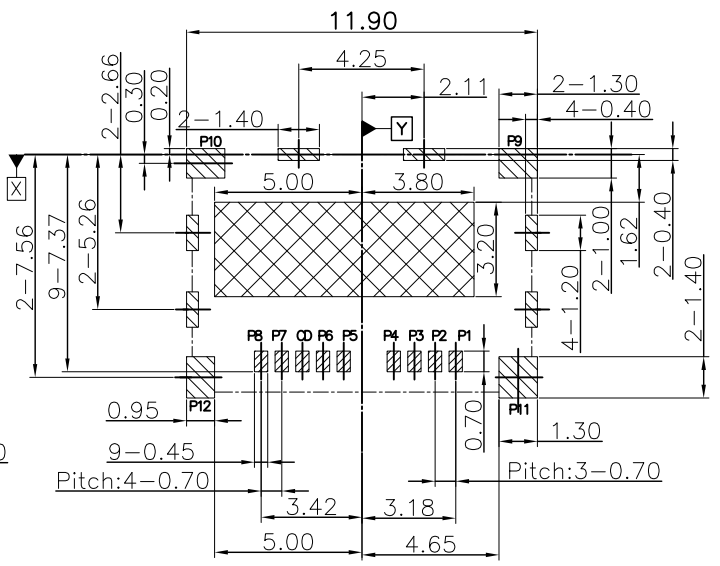

RECOMMEND P.C.B LAYOUT
(General tolerance ±0.05)

- PAD AREA
- KEEP OUT AREA
- NO COPPER AREA
- GND PATTERN ONLY

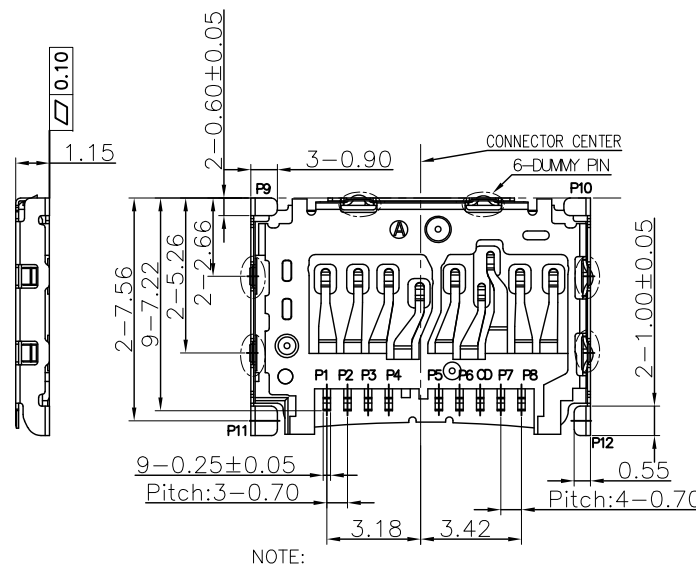
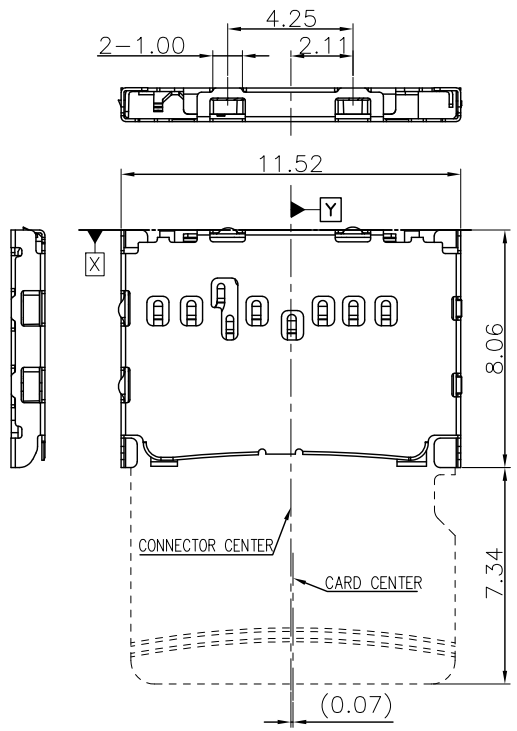
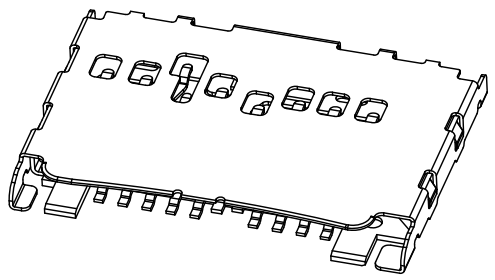
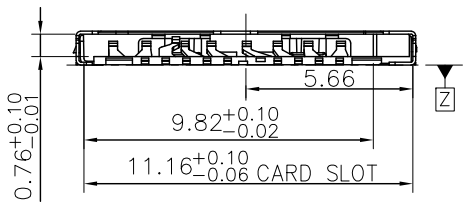

- NOTES:
- MATERIAL:
 - 1.1 PLASTIC: LCP , UL 94V-0, COLOR: BLACK
 - 1.2 CONTACT: COPPER ALLOY
 - 1.3 SHELL: STAINLESS STEEL
 - FINISH:
 - 2.1 TERMINAL: 80u" MIN. NICKEL PLATED OVERALL
 - 2.2 CONTACT: SEE TABLE
 - 2.3 Solder area: G/F.
 - 2.4 SHELL: Solder area: Gold 1u" Min . Ni overall 30u" Min.
 - PRODUCT SPECIFICATION REFER TO SP-A0768-01
 - PACKAGE DRAWING REFER TO PA0768-01
 - PRODUCT MUST CONFORM TO RoHS AND HALOGEN FREE REQUIREMENT

Pin Define	
P1	DAT2
P2	CD/DAT3
P3	CMD
P4	VDD
P5	CLK
P6	VSS
CD	CARD DETECT
P7	DAT0
P8	DAT1
P9-P12	GND

COMPOSITION OF DETECTION

CARD DETECT(SW)

P6 CD

CARD DETECTION/SWITCH

CARD INSTALLATION:ON

NON CARD:OFF

WHEN BECOMIOG SW ON CARD INSTALLATION

TABLE

FIH P/N	TABLE A GOLD PLATING THICKNESS
A0768-0003	Au 30u"
A0768-0001	G/F

PRODUCT SPECIFICATION: DOC.No: SP-A0768-01	SCALE 1 : 1	DESIGN UNITS mm
TEST REPORT DOC.No: TR-A0768-01	DRAWN Mei Chen	DATE 2019/10/07
GENERAL TOLERANCES (UNLESS SPECIFIED)	CHECKED	DATE
X.XXX ± 0.10	APPROVED	DATE
X.XX ± 0.25		
X.X ± 0.38		
ANGULAR ± 3°		
THIRD ANGLE PROJECTION	DWG NO. SA0768-001	

CHT 群匯科技股份有限公司
CHIUN HUEI Technology CO., LTD.

TITLE
Micro SD NON Push Push
Connector Top-Mount,H=1.5

PART NO. SEE TABLE

DWG REV. 02

SHEET NO. 1 OF 1

REVISION HISTORY			
REV	DESCRIPTION	Drawing	DATE
01	PROPOSAL	Mei Chen	2019/10/07

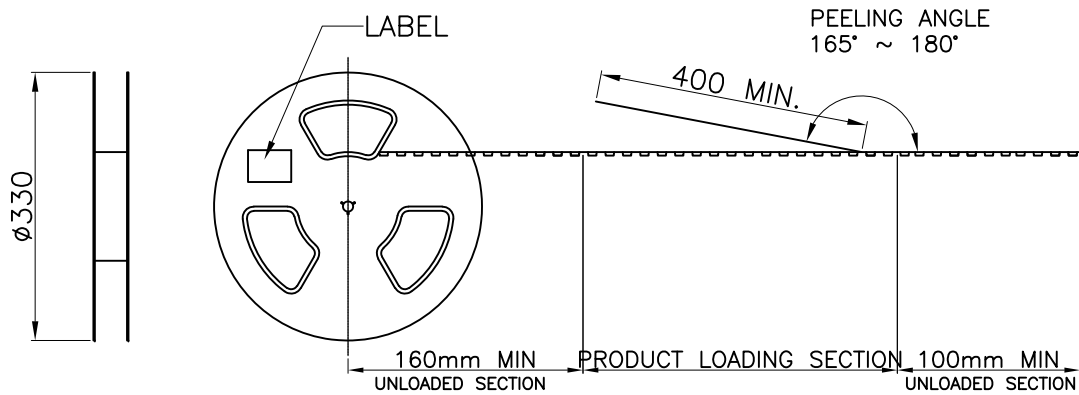
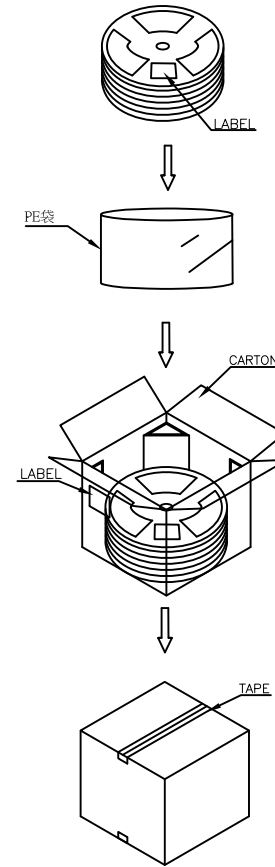
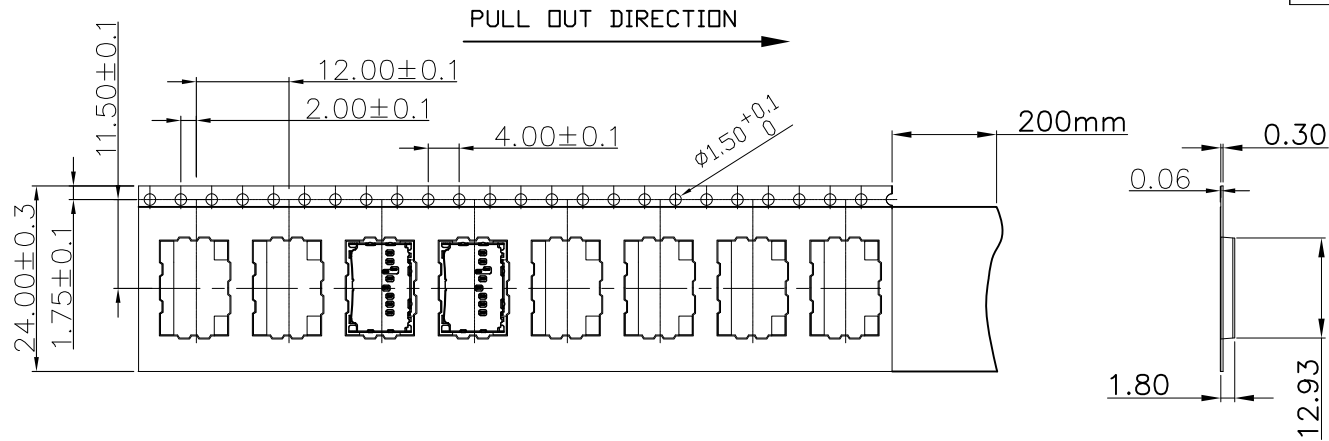

1. COVER TAPE PEELING FORCE:

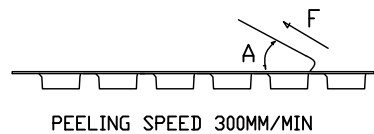

A	15° ~ 0°
F	0.1N ~ 1.3N

2. PART DIMENSIONS MEET EIA-481-D REQUIREMENT

PRODUCT P/N	PARTS PER SHIPPING CARTON	PARTS PER REEL (S.P.Q.)	TOTAL REELS PER SHIPPING CARTON	
A0768-0003	7500(PCS)	2500(PCS)	3	
A0768-0001				
PRODUCT SPECIFICATION: DOC.No: SP-Axxxx-xx	SCALE 1 : 1	DESIGN UNITS mm	CHT 群匯科技股份有限公司 CHIUN HUEI Technology CO., LTD.	
TEST REPORT DOC.No: TR-Axxxx-xx	DRAWN Mei Chen	DATE 2019/10/07		
GENERAL TOLERANCES (UNLESS SPECIFIED)	CHECKED	DATE		
X.XXX ± 0.10	APPROVED	DATE		
X.XX ± 0.25				
X.X ± 0.38			TITLE Micro SD NON Push Push Connector Top-Mount,H=1.5	
ANGULAR ± 3°	DWG NO. PA0768-001	PART NO. SEE TABLE	DWG REV. 01	SHEET NO. 1 OF 1