

REVISION HISTORY			
REV	DESCRIPTION	Drawing	DATE
01	PROPOSAL	Allen	2021/05/10

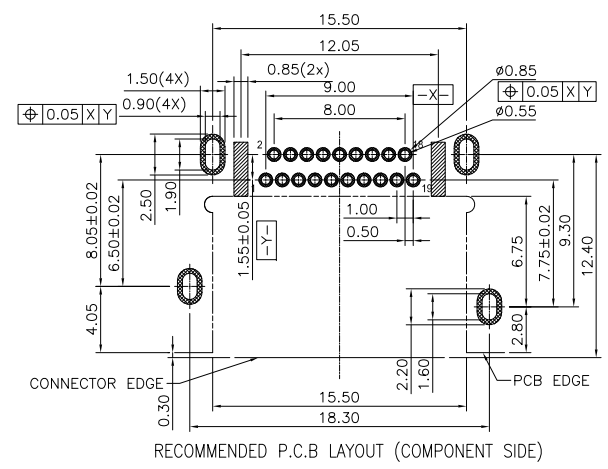

NOTE:
 1. MATERIAL:
 1.1 HOUSING: HIGH TEMPERATURE THERMOPLASTIC, UL94V-0, COLOR:BLACK.
 1.2 CONTACT: COPPER ALLOY.
 1.3 SHELL: METAL.
 2. FINISH:
 2.1 TERMINAL: 50u" MIN. NICKEL PLATED OVERALL
 2.2 CONTACT: SELECTIVE GOLD PLATED, SRR TABLE A.
 2.3 TAIL: 100u" MIN MATT-TIN PLATED.
 2.4 SHELL: 50u" MIN. NICKEL PLATED OVERALL.

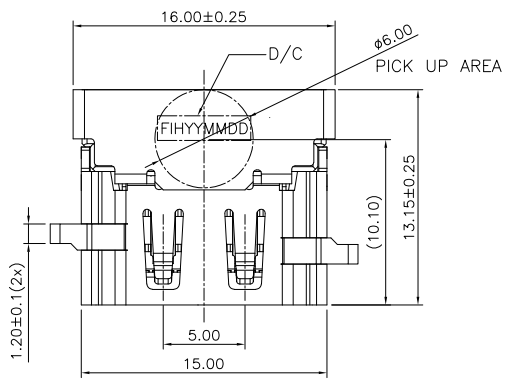
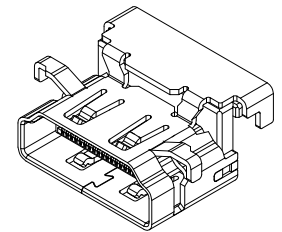
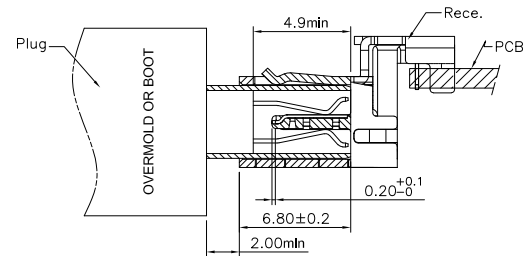
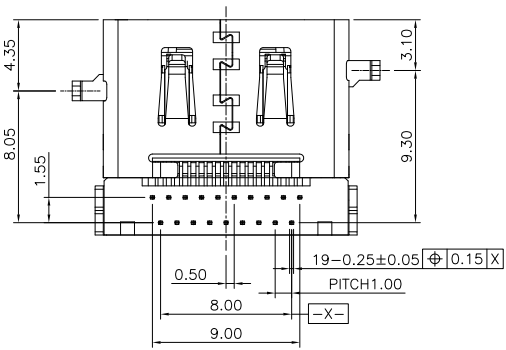
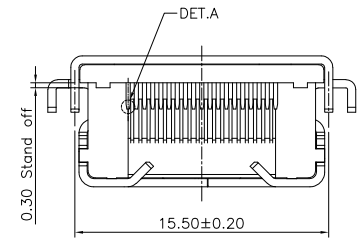
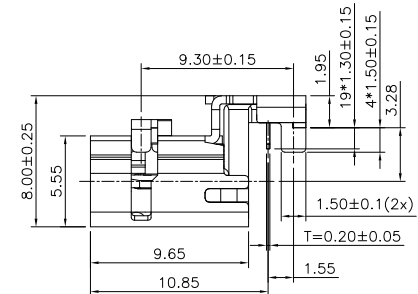
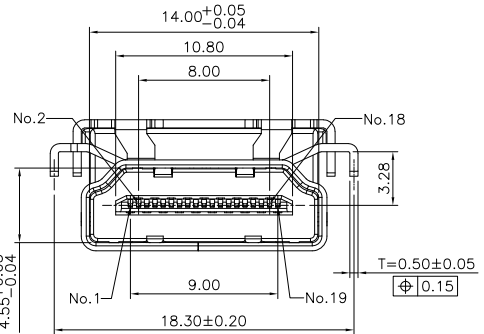

TABLE

FIH P/N	TABLE A GOLD PLATING THICKNESS
A0879-0003	Au30u
A0879-0001	G/F

PRODUCT SPECIFICATION: DOC.No: SP-Axxxx-001	SCALE 1 : 1	DESIGN UNITS mm
TEST REPORT DOC.No: TR-Axxxx-001	DRAWN Allen	DATE 2021/05/10
GENERAL TOLERANCES (UNLESS SPECIFIED)	CHECKED	DATE
X.XXX ± 0.10	APPROVED	DATE
X.XX ± 0.25		
X.X ± 0.38		
ANGULAR ± 3°		
THIRD ANGLE PROJECTION	DWG NO. SA0879-001	PART NO. TABLE A

FULLINHOPE Technology, LTD.

TITLE
 HDMI A TYPE REVERSE,
 SINK , C/H=-3.28mm

PART NO. TABLE A	DWG REV. 01	SHEET NO. 1 OF 1
---------------------	----------------	---------------------