

REVISION HISTORY			
REV	DESCRIPTION	Drawing	DATE
04	增加標柱尺寸	Allen	2019/11/25

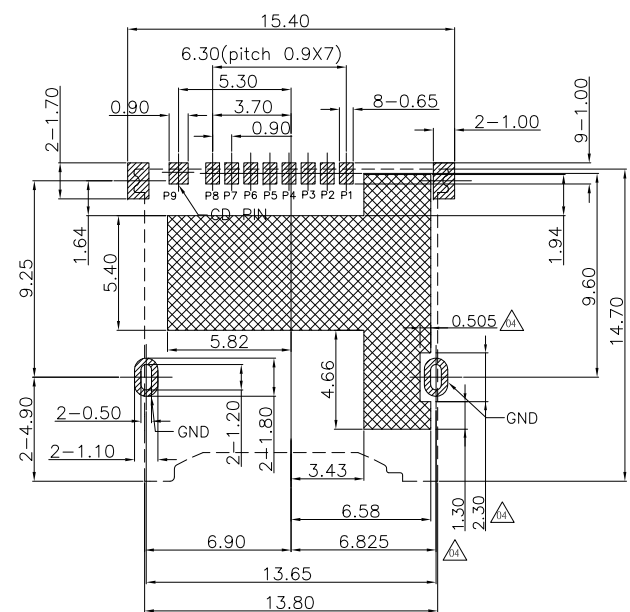
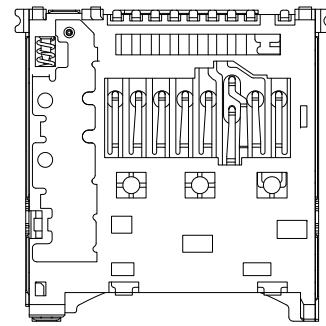
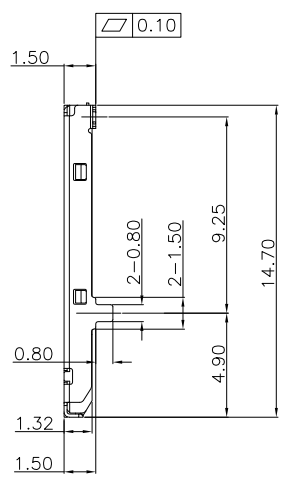
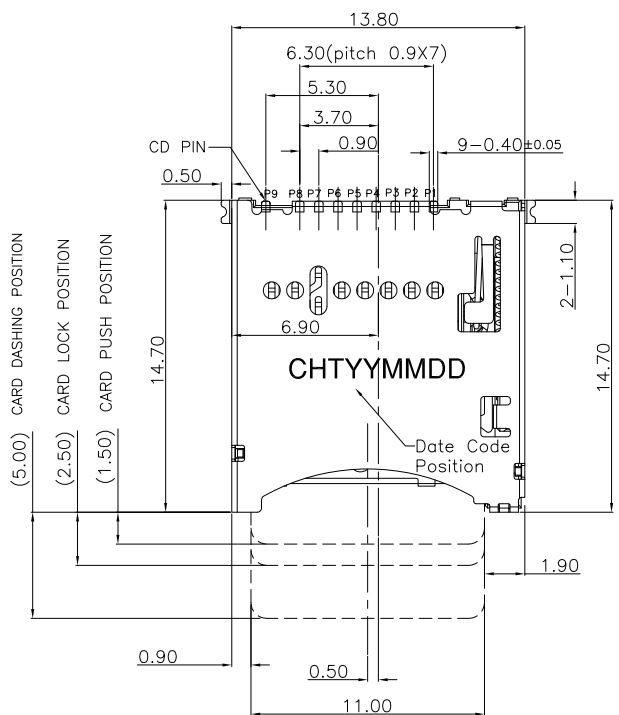

PCB PATTERN LAYOUT  
(GENERAL TOLERANCE:±0.05)

▨ PAD AREA    ⊗ No trace, no test point, no via hole, no ground area

- △ NOTES:
- MATERIAL:
    - 1.1 PLASTIC: LCP, UL 94V-0, COLOR: BLACK
    - 1.2 CONTACT: COPPER ALLOY
    - 1.3 SHELL: STAINLESS STEEL
  - FINISH:
    - 2.1 TERMINAL: 50μ" MIN. NICKEL PLATED OVERALL
    - 2.2 CONTACT: SELECTIVE GOLD PLATED, SEE TABLE A
    - 2.3 TAIL: 80μ" MATT-TIN PLATED
    - 2.4 SHELL: 50μ" MIN. NICKEL PLATED OVERALL
  - PRODUCT SPECIFICATION REFER TO SP-A0736-01
  - PACKAGE DRAWING REFER TO PA0736-01
  - PRODUCT MUST CONFORM TO RoHS AND HALOGEN FREE REQUIREMENT

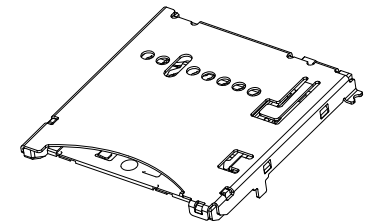
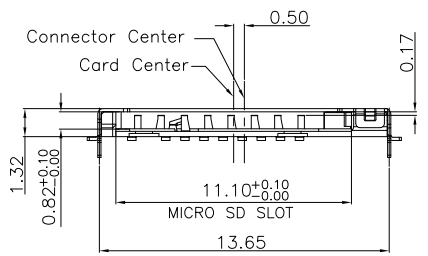

Pin Define

P1	DAT2
P2	CD/DAT3
P3	CMD
P4	VDD
P5	CLK
P6	VSS
P7	DAT0
P8	DAT1
P9	CD

COMPOSITION OF DETECTION

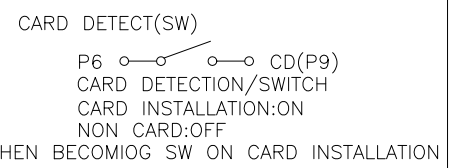

TABLE

FIH P/N	TABLE A GOLD PLATING THICKNESS
A0736-0003	Au30u
A0736-0001	G/F

PRODUCT SPECIFICATION: DOC.No: SP-A0736-01 TEST REPORT DOC.No: TR-A0736-01 GENERAL TOLERANCES (UNLESS SPECIFIED)	SCALE 1 : 1	DESIGN UNITS mm
X.XXX ± 0.10 X.XX ± 0.25 X.X ± 0.38	DRAWN Mei Chen	DATE 2019/06/28
ANGULAR ± 3°	CHECKED	DATE
THIRD ANGLE PROJECTION	APPROVED	DATE
	DWG NO. SA0736-001	

**CHT** 群匯科技股份有限公司  
CHIUN HUEI Technology CO., LTD.

TITLE  
Micro SD Push Push Connector  
Top-Mount,H=1.5

PART NO. TABLE A	DWG REV. 04	SHEET NO. 1 OF 1
---------------------	----------------	---------------------

REVISION HISTORY			
REV	DESCRIPTION	Drawing	DATE
01	PROPOSAL	Mei Chen	2019/10/04

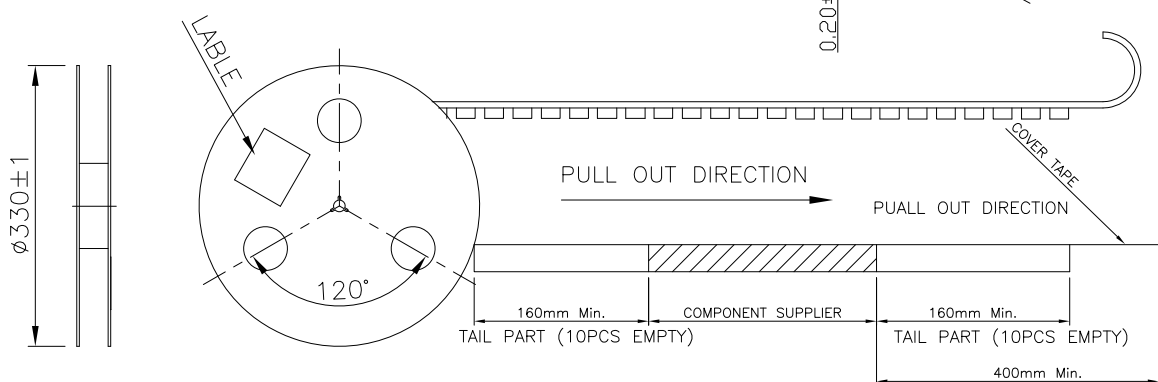
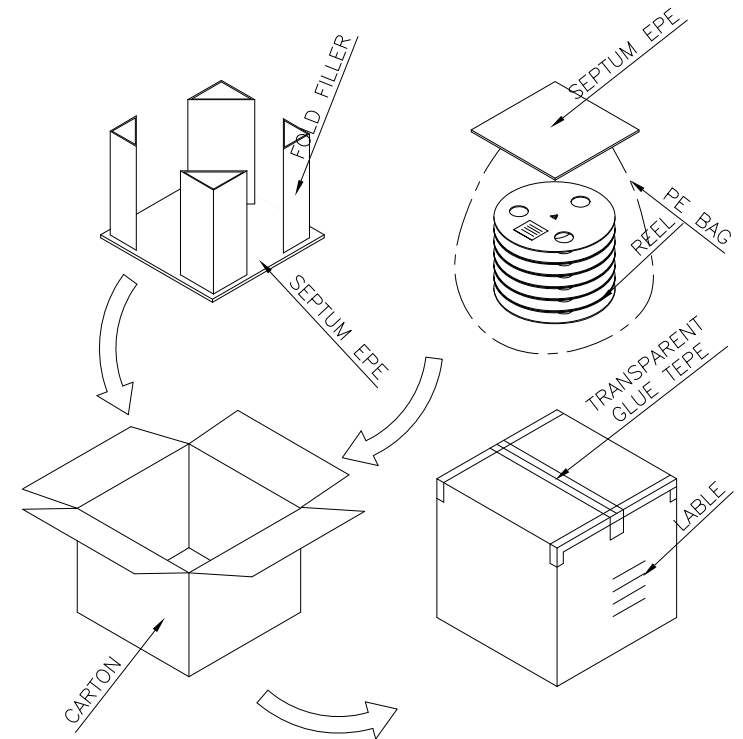
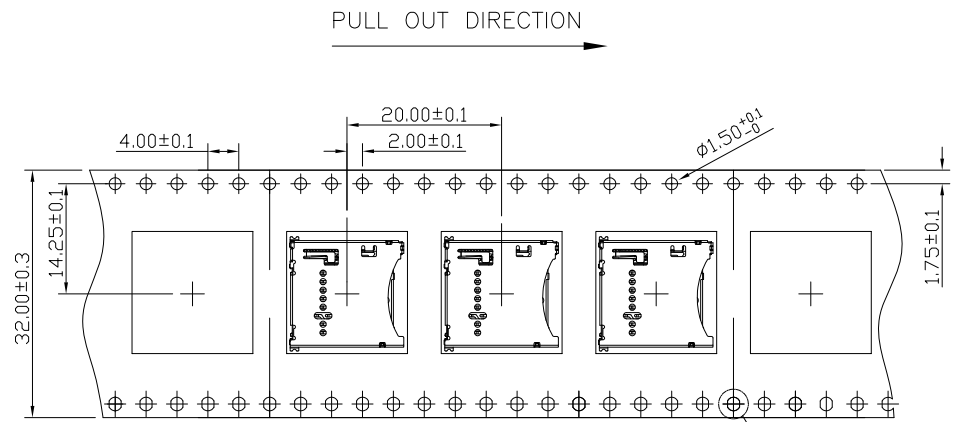

1. COVER TAPE PEELING FORCE:

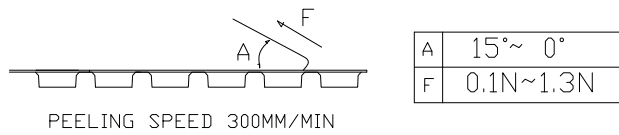

2. PART DIMENSIONS MEET EIA-481-2-A REQUIREMENT

PRODUCT P/N	PARTS PER SHIPPING CARTON	PARTS PER REEL (S.P.Q.)	TOTAL REELS PER SHIPPING CARTON
A0736-0003	14000(PCS)	1400(PCS)	10
A0736-0001			
PRODUCT SPECIFICATION DOC.No: SP-Axxxx-xx	SCALE 1 : 1	DESIGN UNITS mm	<b>CHT</b> 群匯科技股份有限公司 CHIUN HUEI Technology CO., LTD.
TEST REPORT DOC.No: TR-Axxxx-xx	DRAWN Mei Chen	DATE 2019/08/22	
GENERAL TOLERANCES (UNLESS SPECIFIED)	CHECKED	DATE	
X.XXX ± 0.10	APPROVED	DATE	
X.XX ± 0.25			TITLE Micro SD Push Push Connector Top-Mount,H=1.5
XX ± 0.38			
ANGULAR ± 3°			
THIRD ANGLE PROJECTION	DWG NO. PA0736-001	PART NO. A0736-0001	DWG REV. 01
			SHEET NO. 1 OF 1