

REVISION HISTORY			
REV	DESCRIPTION	Drawing	DATE
A	RELEASE	Mei Chen	2013/07/22

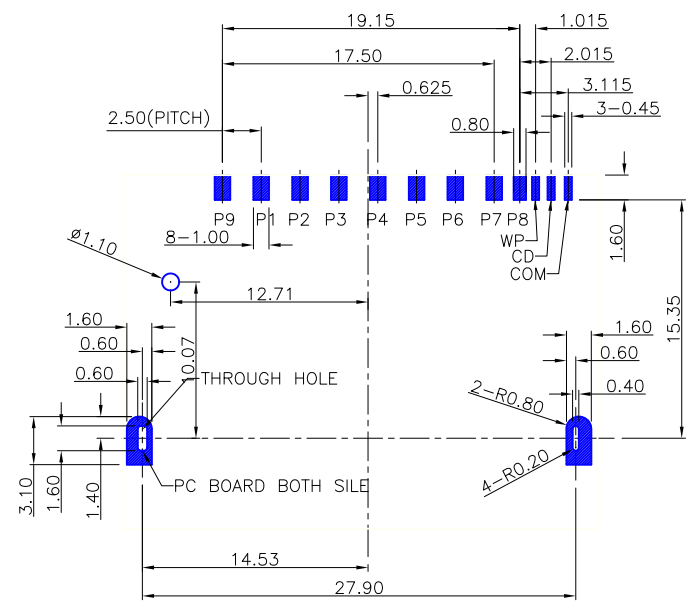

RECOMMEND P.C.B LAYOUT
GENERAL TOLERANCE ±0.05

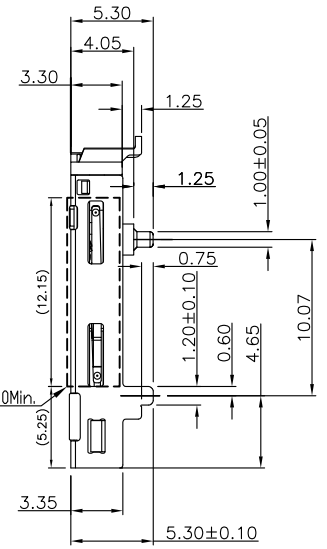
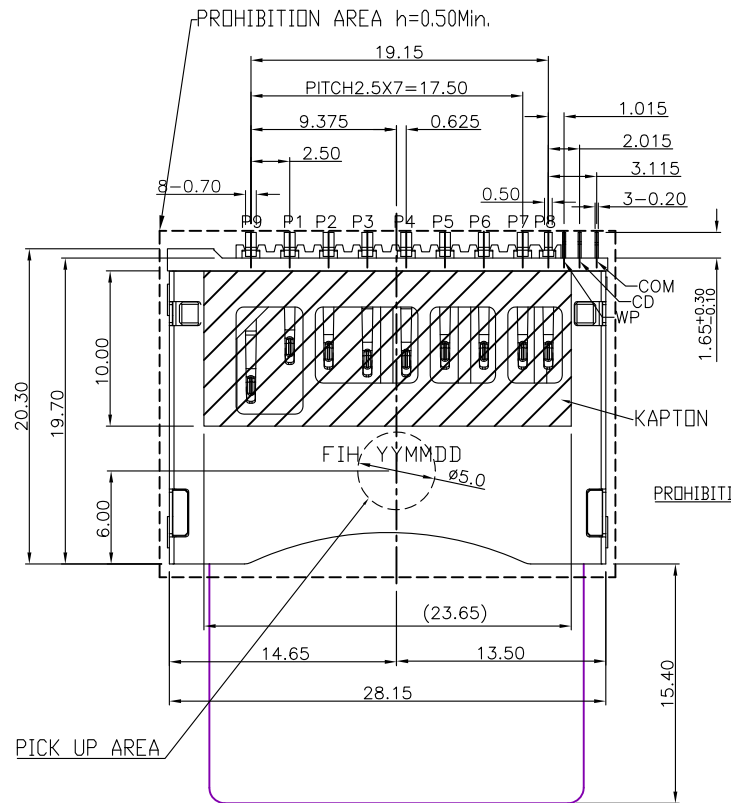
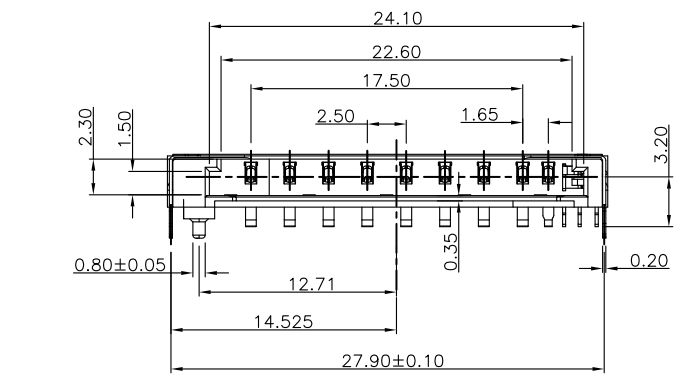

PIN NO.	SD NAME	MMC NAME
P1	CD/DAT3	RSV
P2	CMD	CMD
P3	VSS	VSS
P4	VDD	VDD
P5	CLK	CLK
P6	VSS	VSS
P7	DAT0	DAT
P8	DAT1	DAT
P9	DAT2	DAT

- NOTES:
- MATERIAL:
 - HOUSING: LCP E6808 UL94 V-0
COLOR: BLACK.
 - CONTACT: C5210
 - SHELL: SUS304
 - KAPTON: PI FILM, HIGH TEMP.
 - PLATING:
 - CONTACT: GOLD FLASH ON CONTACT AREA
100 μ" MIN. MATTE-TIN ON SOLDERING TAILS
50 μ" MIN. NICKEL UNDERPLATING OVER ALL
 - SHELL: 50 μ" MIN. NICKEL UNDERPLATING OVER ALL
 - PACKAGING DRAWING REFER TO PA0131-001
 - DATE:YY<YEAR>,MM<MONTH>,DD<DATE>.

WITHOUT CARD	CD CD/WP COM WP CD/WP COM
INSERTED CARD(UNLOCK)	CD CD/WP COM WP CD/WP COM
INSERTED CARD(LOCK)	CD CD/WP COM WP CD/WP COM

PRODUCT SPECIFICATION: DOC.No: SP-AXXXX-XX	SCALE 1 : 1	DESIGN UNITS mm	FULLINHOPE Technology, LTD.	
TEST REPORT DOC.No: TR-AXXXX-XX	DRAWN Ray Lee	DATE 2013/02/06	TITLE SD CARD NON PUSH-PUSH	
GENERAL TOLERANCES (UNLESS SPECIFIED)	CHECKED	DATE		
X.XXX ± 0.20	APPROVED	DATE		
X.XX ± 0.20				
X.X ± 0.25				
ANGULAR ± 3°				
THIRD ANGLE PROJECTION	DWG NO. SA0131-001	PART NO. A0131-0001	DWG REV. A	SHEET NO. 1 OF 1

REVISION HISTORY			
REV	DESCRIPTION	Drawing	DATE
A	RELEASE	Mei Chen	2013/09/27

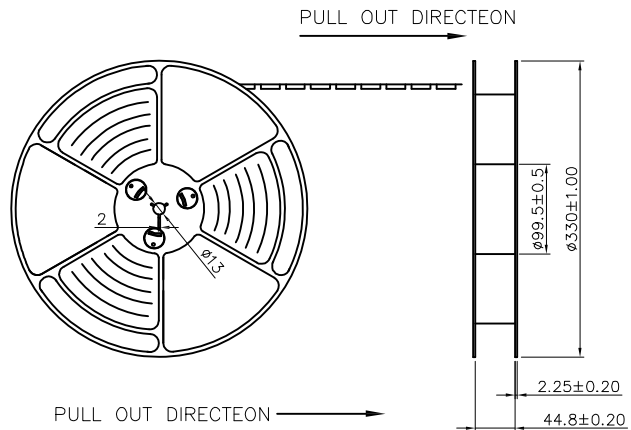

Location of label sticking (label at small positioning hole of the carrier tape side).

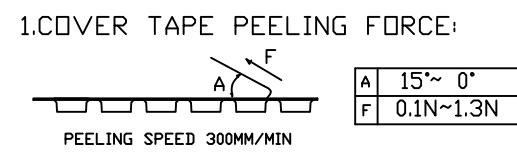
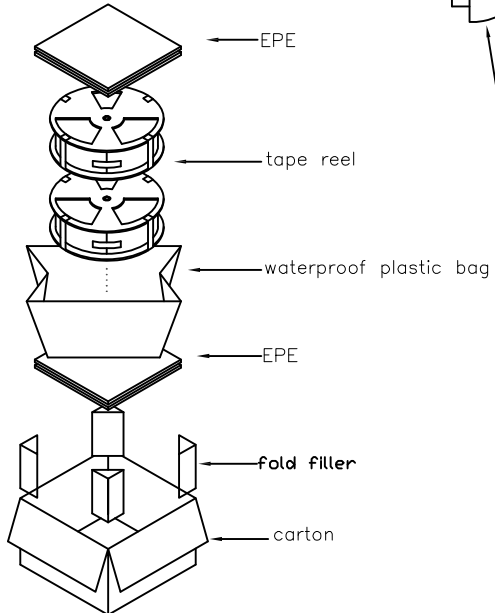
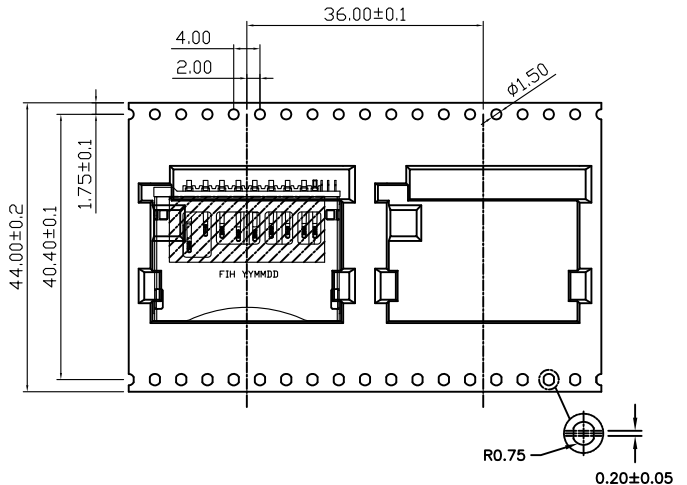
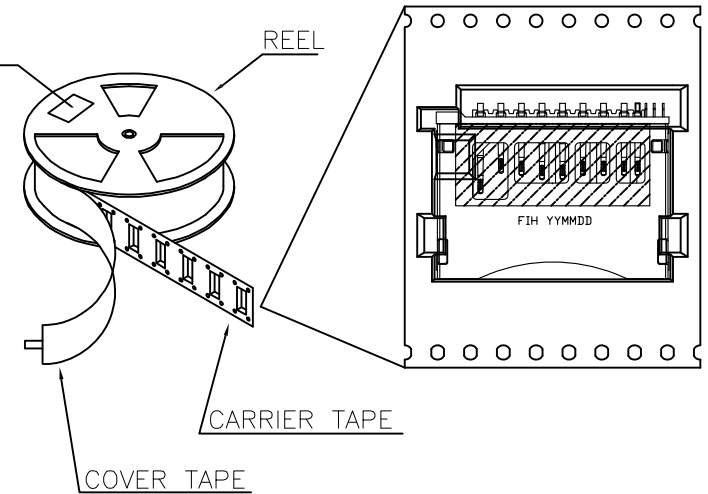

2. PART DIMENSIONS MEET EIA-481-2-A REQUIREMENT

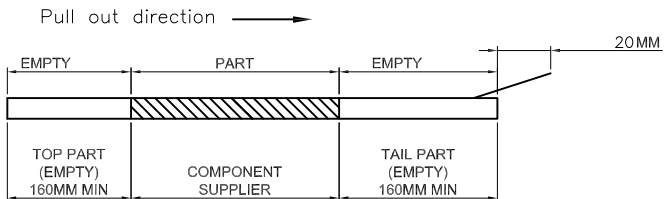

PRODUCT P/N	PARTS PER SHIPPING CARTON	PARTS PER REEL (S.P.Q.)	TOTAL REELS PER SHIPPING CARTON
A0131-0001	1000(PCS)	200(PCS)	5

PRODUCT SPECIFICATION: DOC.No. SP-AXXXX-XX	SCALE 1 : 1	DESIGN UNITS mm	FULLINHOPE Technology, LTD.	
TEST REPORT DOC.No. TR-AXXXX-XX	DRAWN IRIS WU	DATE 2012/11/28	TITLE SD CARD NON PUSH-PUSH	
GENERAL TOLERANCES (UNLESS SPECIFIED)	CHECKED	DATE		
X.XXX ± 0.20	APPROVED	DATE		
X.XX ± 0.20				
X.X ± 0.25				
ANGULAR ± 3°	DWG NO. PA0131-001	PART NO. A0131-0001	DWG REV. A	SHEET NO. 1 OF 1
THIRD ANGLE PROJECTION				