

REVISION HISTORY			
REV	DESCRIPTION	Drawing	DATE
05	修改尺寸	ALLEN	2020/04/27

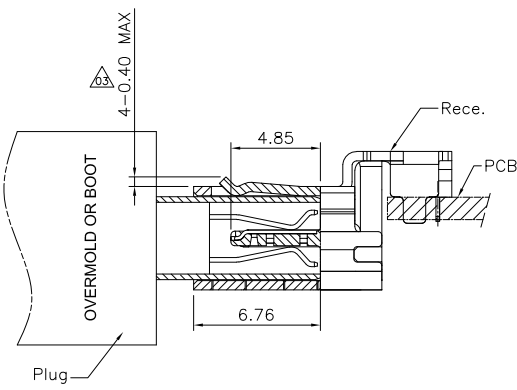

Mated Condition

RECOMMENDED PCB LAYOUT VIEW
(THICKNESS = 1.2±0.10mm)
(TOLERANCE ±0.05mm)

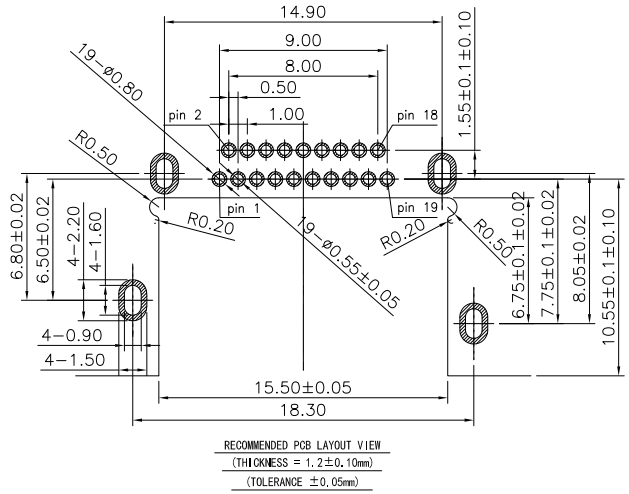
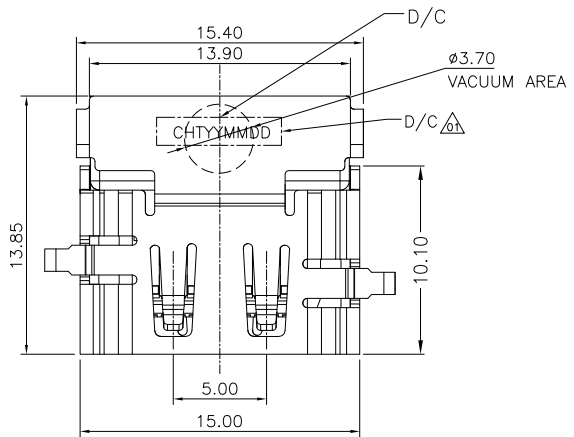
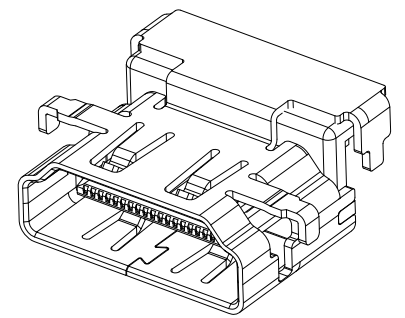
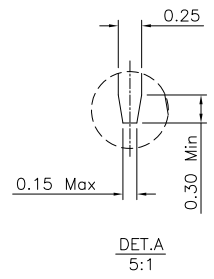
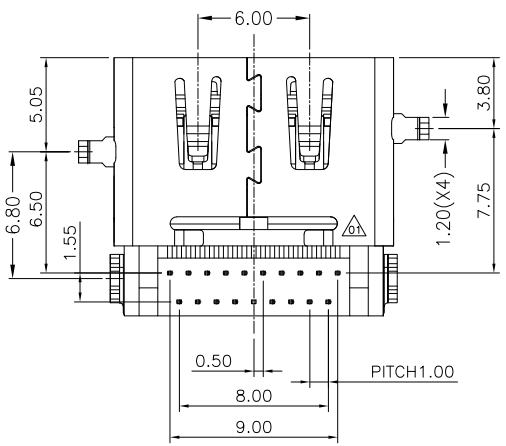
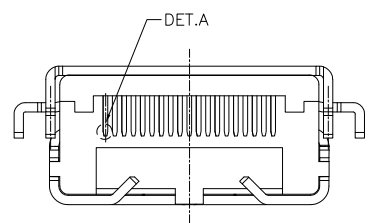
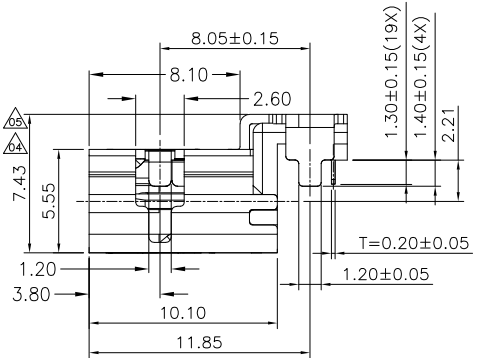
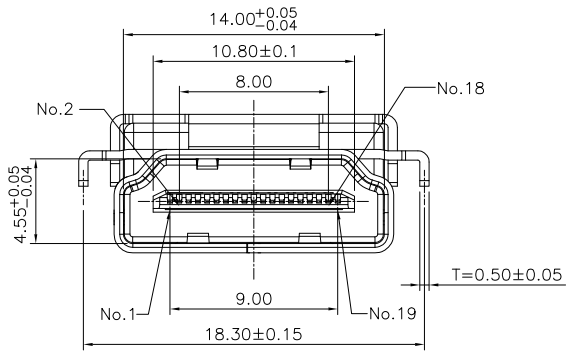

PRODUCT SPECIFICATION: DOC.No: SP-Axxxx-xx	SCALE 1 : 1	DESIGN UNITS mm
TEST REPRDT DOC.No: TR-Axxxx-xx	DRAWN ALLEN	DATE 2020/01/20
GENERAL TOLERANCES (UNLESS SPECIFIED)	CHECKED	DATE
X.XXX ± 0.10	APPROVED	DATE
X.XX ± 0.25	DWG NO. SA0798-001	
X.X ± 0.38		
ANGULAR ± 3°		
THIRD ANGLE PROJECTION		

CHT 群匯科技股份有限公司
CHIUN HUEI Technology CO., LTD.

TITLE
HDMI A RVS CH = -2.21

TABLE	
FIH P/N	TABLE A GOLD PLATING THICKNESS
A0798-0003	Au 30u"
A0798-0001	G/F

PART NO. TABLE A	DWG REV. 05	SHEET NO. 1 OF 1
---------------------	----------------	---------------------

REVISION HISTORY			
REV	DESCRIPTION	Drawing	DATE
01	PROPOSAL	Allen	2020/04/09

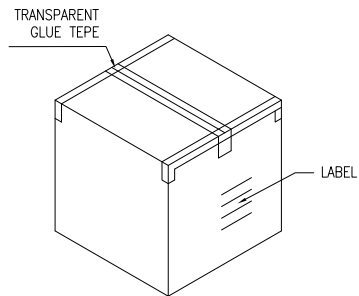
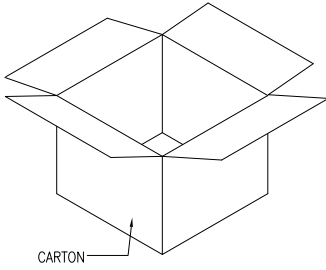
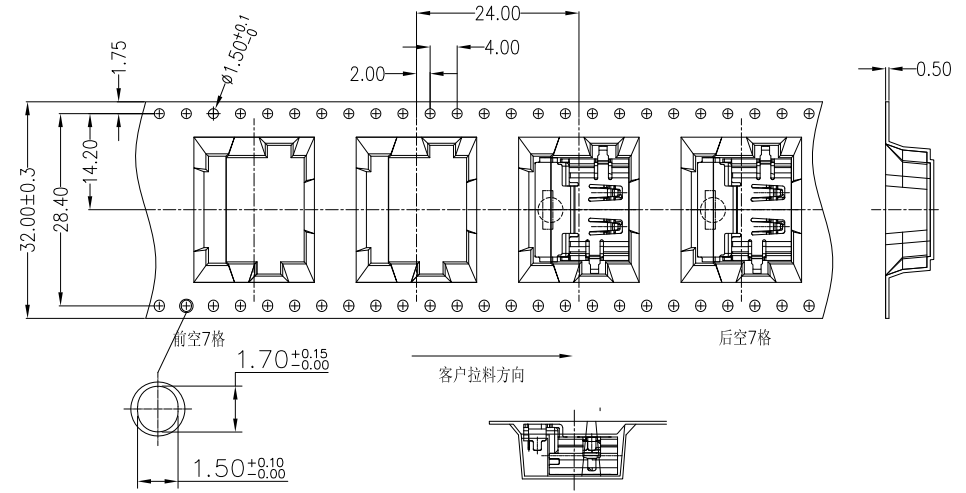
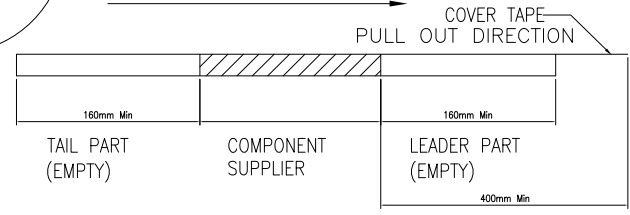
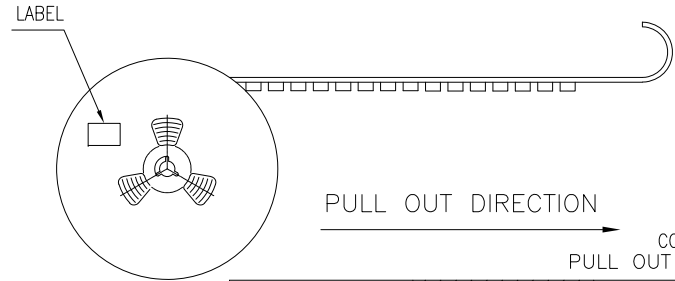
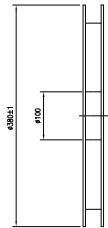
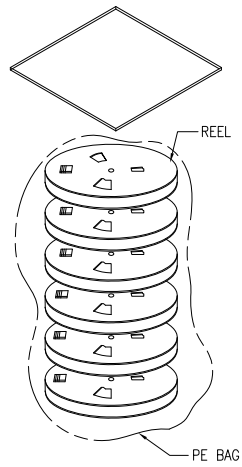
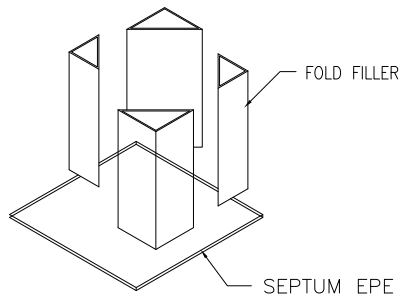

TABLE

PRODUCT P/N	PARTS PER SHIPPING CARTON	PARTS PER REEL	LOADED REEL PER SHIPPING CARTON
A0798-0003	4500	450	10
A0798-0001			

1. COVER TAPE PEELING FORCE:

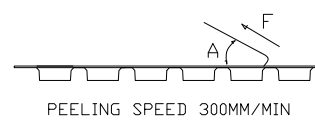

A	15°~ 0°
F	0.1N~1.3N

PEELING SPEED 300MM/MIN

2. PART DIMENSIONS MEET EIA-481-2-A REQUIREMENT

PRODUCT SPECIFICATION: DOC.No: SP-Axxxx-xx	SCALE 1 : 1	DESIGN UNITS mm	CHT 群匯科技股份有限公司 CHIUN HUEI Technology CO., LTD.	
TEST REPORT DOC.No: TR-Axxxx-xx	DRAWN Allen	DATE 2020/04/09		
GENERAL TOLERANCES (UNLESS SPECIFIED)	X.XXX ± 0.10	CHECKED	DATE	
	X.XX ± 0.25	APPROVED	DATE	
	X.X ± 0.38	ANGULAR	± 3°	
THIRD ANGLE PROJECTION	DWG NO. PA0798-001	PART NO. SEE TABLE	DWG REV. 01	SHEET NO. 1 OF 1