

REVISION HISTORY			
REV	DESCRIPTION	Drawing	DATE
01	PROPOSAL	Mei Chen	2017/03/06

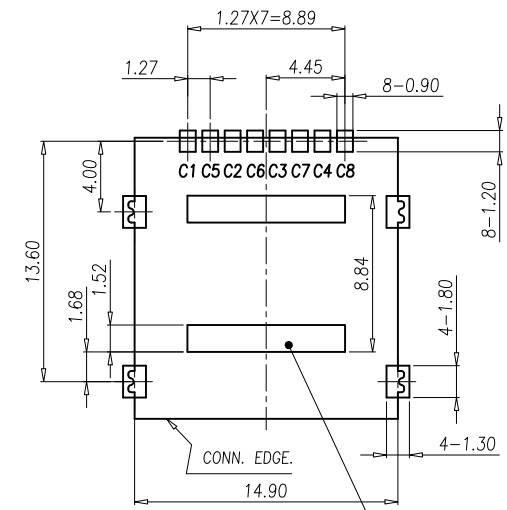

RECOMMENDED PCB LAYOUT
 GENERAY TOLERANCE ±0.05

禁布区域：此区域内为端子头部下压区域
 区域内不可有任何线路及铜箔

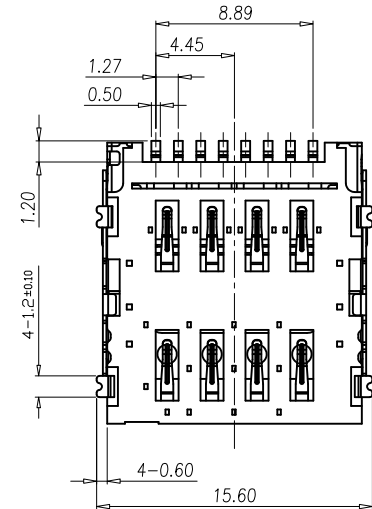
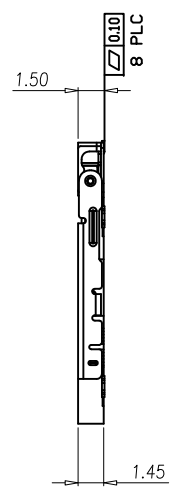
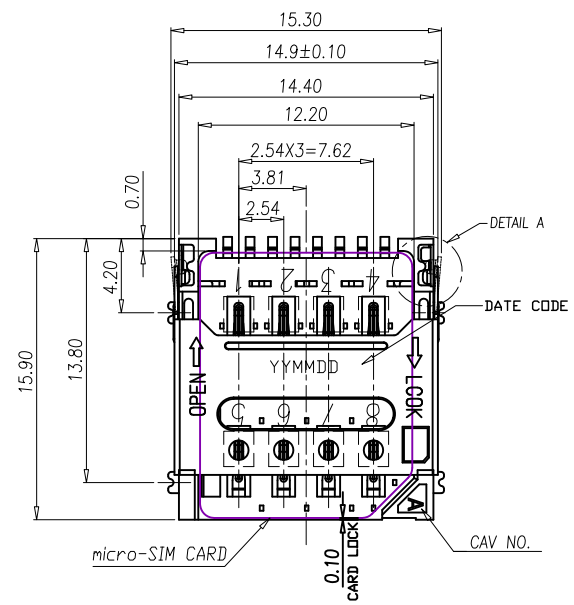
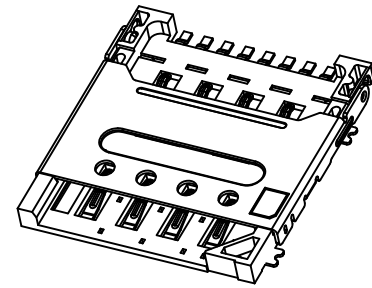
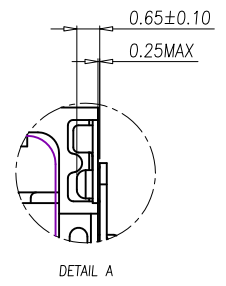
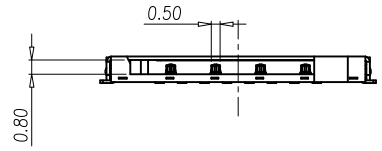

- NOTES:
- MATERIAL:
 - 1.1 PLASTIC: THERMOPLASTIC, UL 94V-0, COLOR: BLACK
 - 1.2 CONTACT: COPPER ALLOY,
 - 1.3 SHELL: STAINLESS STEEL
 - FINISH:
 - 2.1 TERMINAL: 50u" MIN. NICKEL PLATED OVERALL
 - 2.2 CONTACT: SELECTIVE GOLD PLATED, SEE TABLE A
 - 2.3 TAIL: 100u" MATT-TIN PLATED
 - PRODUCT SPECIFICATION REFER TO SP-A0483-01
 - PACKAGE DRAWING REFER TO PA0483-01
 - PRODUCT MUST CONFORM TO RoHS AND HALOGEN FREE REQUIREMENT

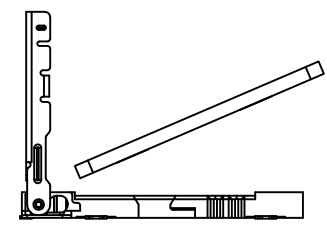

STEP 1 INSERT Micro-SIM CARD

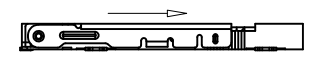

STEP 2 PUSH THE SHELL

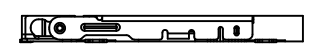

STEP 3 FINISH

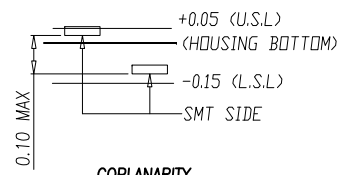

COPLANARITY

TABLE

FIH P/N	TABLE A GOLD PLATING THICKNESS
A0528-0003	Au30u
A0528-0001	G/F

MICRO SIM CARD		PRODUCT SPECIFICATION: DOC.No: SP-A0483-01 TEST REPORT DOC.No: TR-A0483-01	SCALE 1 : 1	DESIGN UNITS mm
PIN NO.	DESCRIPTION			
C1	VCC	GENERAL TOLERANCES (UNLESS SPECIFIED)	DRAWN Mei Chen	DATE 2017/07/21
C2	RST			
C3	CLK		CHECKED	DATE
C4	RESERVED		APPROVED	DATE
C5	GND			
C6	VPP		DWG NO. SA0483-001	THIRD ANGLE PROJECTION
C7	I/O			
C8	RESERVED			

CHT 群匯科技股份有限公司
 CHIUN HUEI Technology CO., LTD.

TITLE
 MICRO SIM CARD CONNECTOR
 HINGE TYPE H=1.5

PART NO. SEE TASLE	DWG REV. 01	SHEET NO. 1 OF 1
-----------------------	----------------	---------------------

REVISION HISTORY			
REV	DESCRIPTION	Drawing	DATE
01	PROPOSAL	Mei Chen	2018/03/26

GATHER MATERIAL DIRECTION ← INPUT MATERIAL DIRECTION →

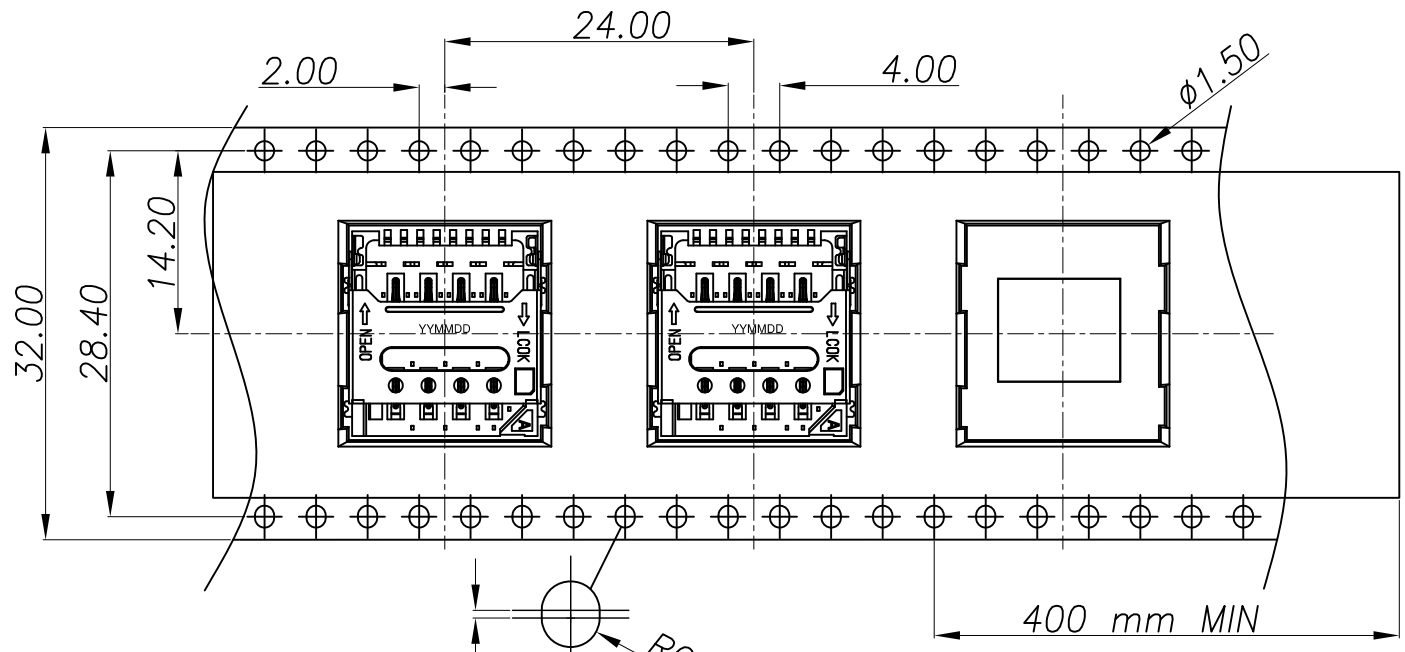

1. COVER TAPE PEELING FORCE:

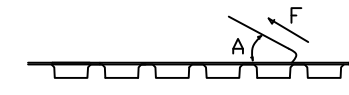

A	15°~ 0°
F	0.1N~1.3N

PEELING SPEED 200MM/MIN

2. PART DIMENSIONS MEET EIA-481-2-A REQUIREMENT

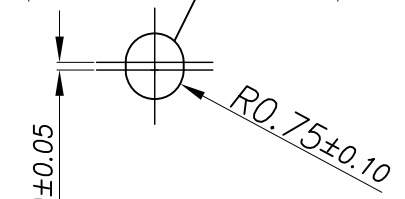
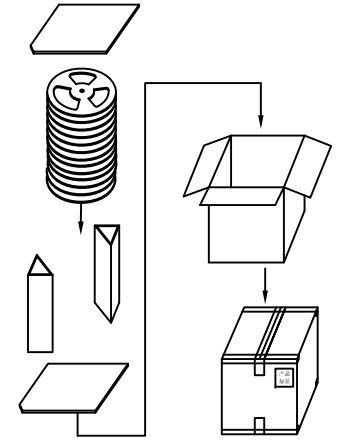

PULL OUT DIRECTION →

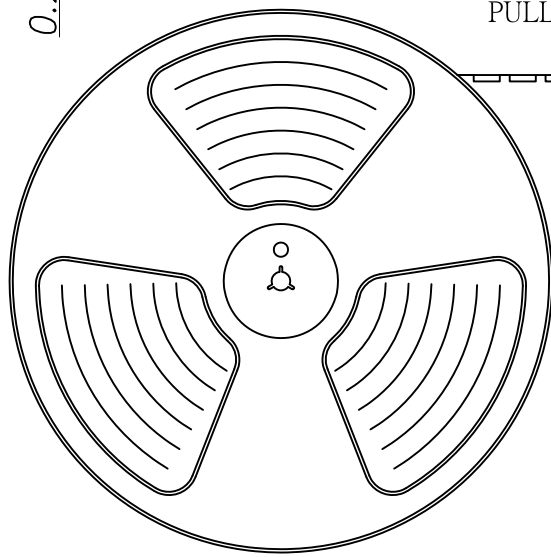
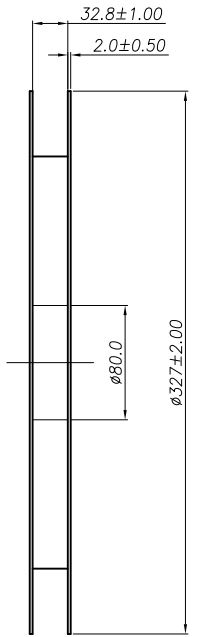

TABLE

PRODUCT P/N	PARTS PER SHIPPING CARTON	PARTS PER REEL (S.P.Q.)	TOTAL REELS PER SHIPPING CARTON
A0483-0003	8000(PCS)	1000(PCS)	8
A0483-0001			

PRODUCT SPECIFICATION: DOC.No: SP-Axxxx-xx	SCALE 1 : 1	DESIGN UNITS mm
TEST REPORT DOC.No: TR-Axxxx-xx	DRAWN Mei Chen	DATE 2018/03/26
GENERAL TOLERANCES (UNLESS SPECIFIED)	CHECKED	DATE
X.XXX ± 0.10	APPROVED	DATE
X.XX ± 0.25	ANGULAR ± 3°	
X.X ± 0.38	DWG NO. PA0483-001	PART NO. SEE TABLE
THIRD ANGLE PROJECTION	DWG REV. 01	SHEET NO. 1 OF 1

CHT 群匯科技股份有限公司
CHIUN HUEI Technology CO., LTD.

TITLE
MICRO SIM CARD CONNECTOR
HINGE TYPE H=1.5